



(19) **United States**

(12) **Patent Application Publication**
Kwak et al.

(10) **Pub. No.: US 2011/0108844 A1**
(43) **Pub. Date: May 12, 2011**

(54) **ORGANIC LIGHT EMITTING DISPLAY**

(30) **Foreign Application Priority Data**

(75) Inventors: **Won-Kyu Kwak, Yongin-city (KR);
Yang-Wan Kim, Yongin-city (KR)**

May 12, 2005 (KR) 10-2005-0039895

Publication Classification

(73) Assignee: **Samsung Mobile Display Co.,
Ltd., Yongin-city (KR)**

(51) **Int. Cl.**
H01L 51/50 (2006.01)

(52) **U.S. Cl.** **257/71; 257/E51.018**

(21) Appl. No.: **13/007,371**

(57) **ABSTRACT**

(22) Filed: **Jan. 14, 2011**

An organic light emitting display (OLED) is disclosed. The OLED includes a storage capacitor formed in a first region of the substrate, a thin film transistor formed in a second region of the substrate, a first data line capacitor formed in a third region of the substrate, an organic light emitting diode formed on the storage capacitor and the thin film transistor, and a second data line capacitor formed on the data line capacitor.

Related U.S. Application Data

(62) Division of application No. 11/432,598, filed on May 11, 2006.

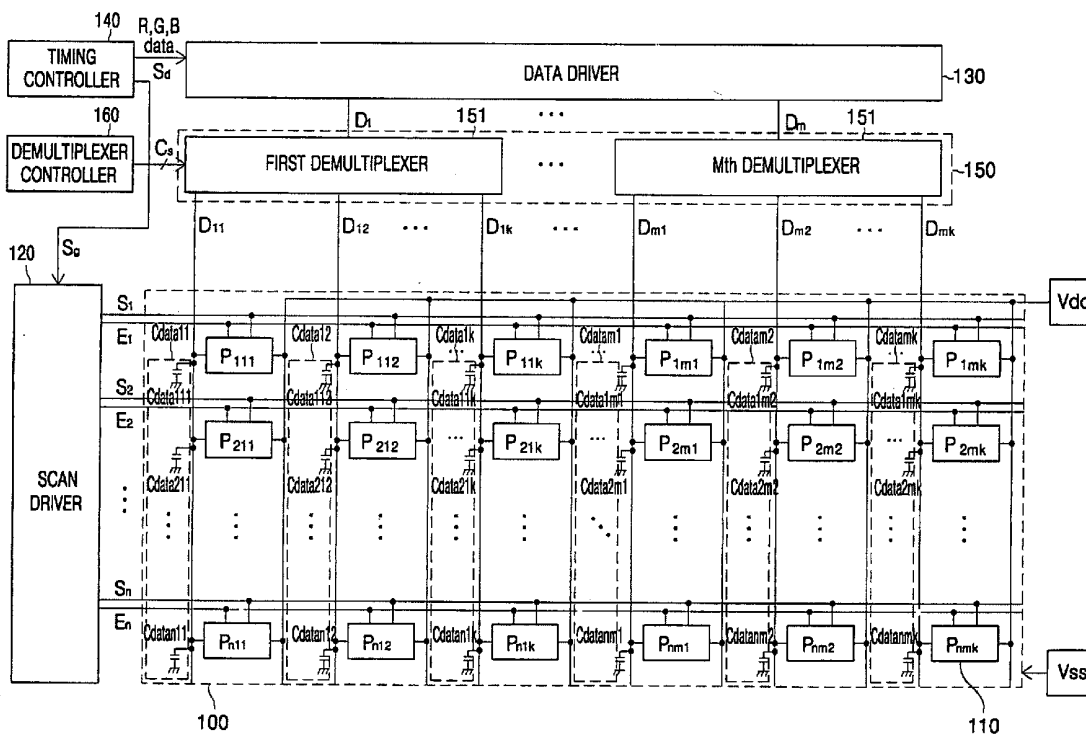

FIG. 1
(PRIOR ART)

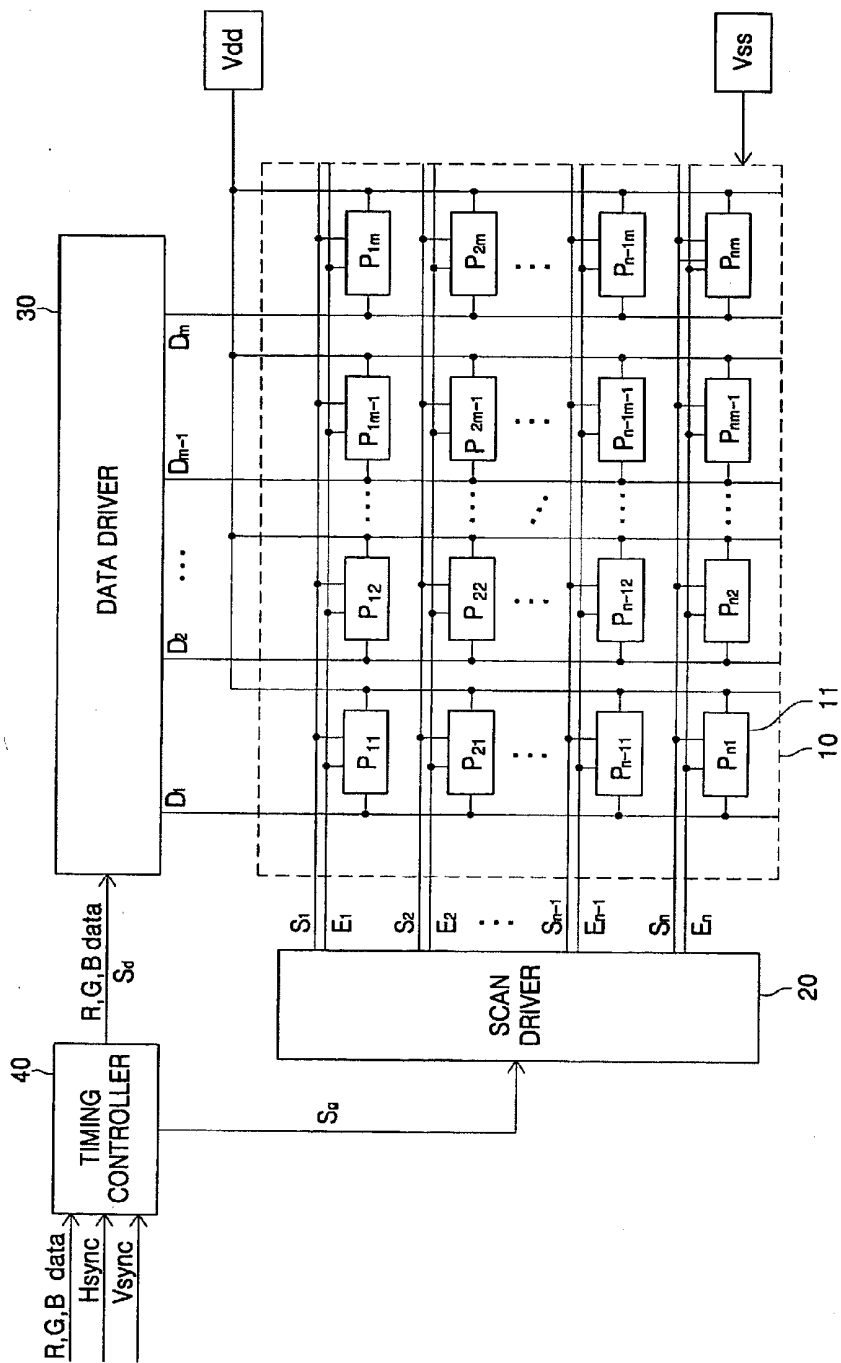

FIG. 2

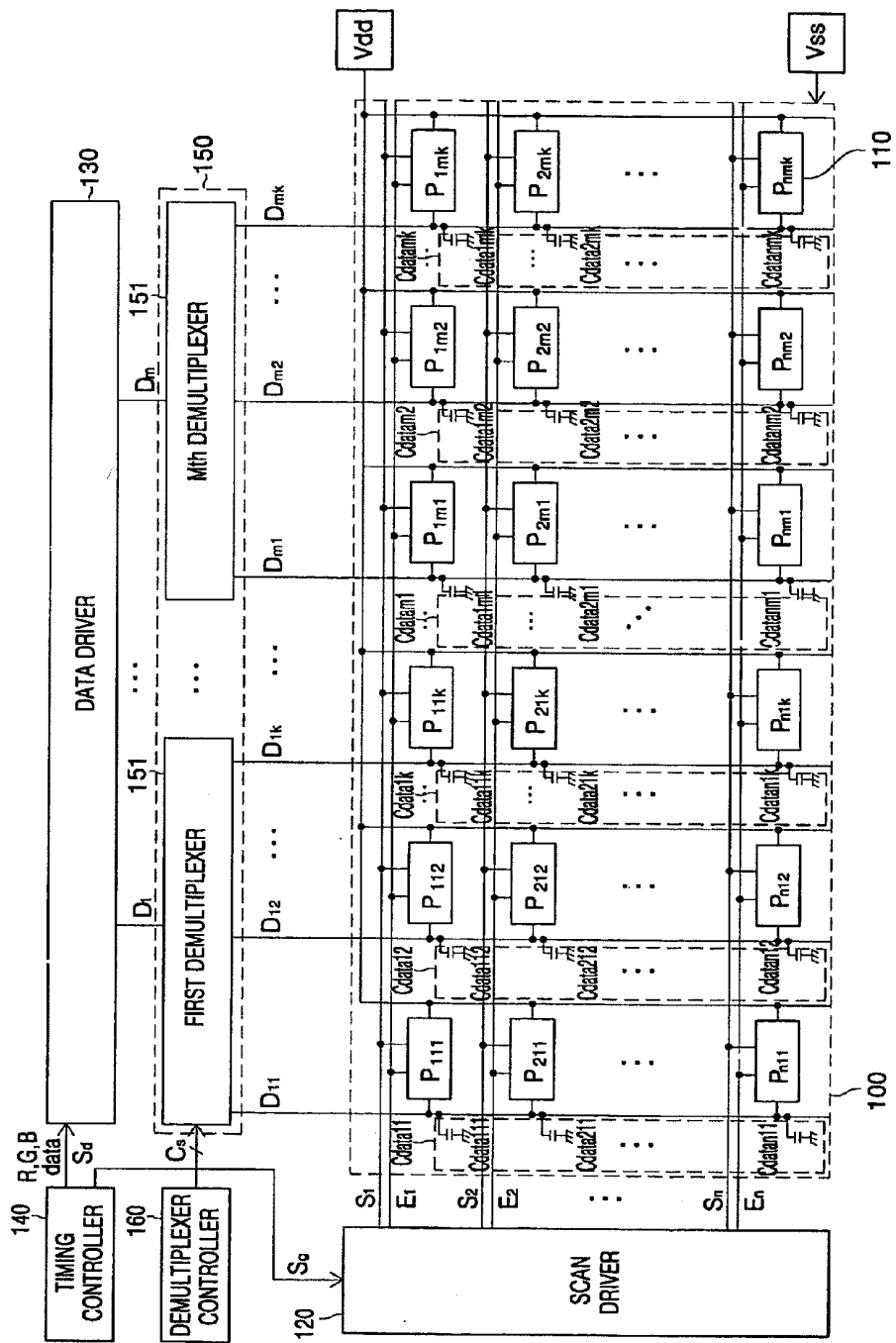

FIG. 3

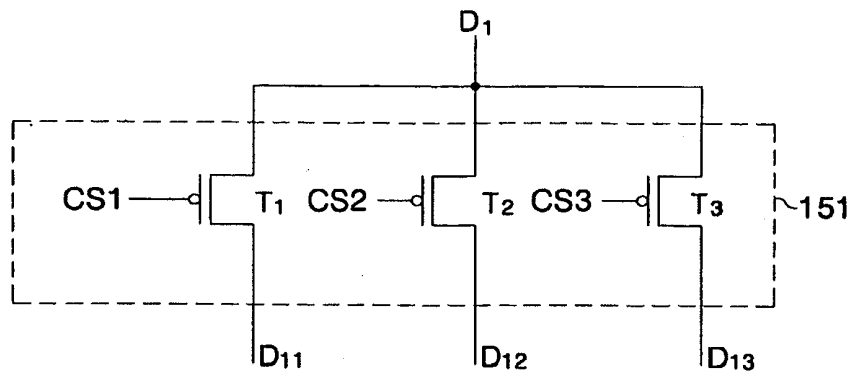

FIG. 4

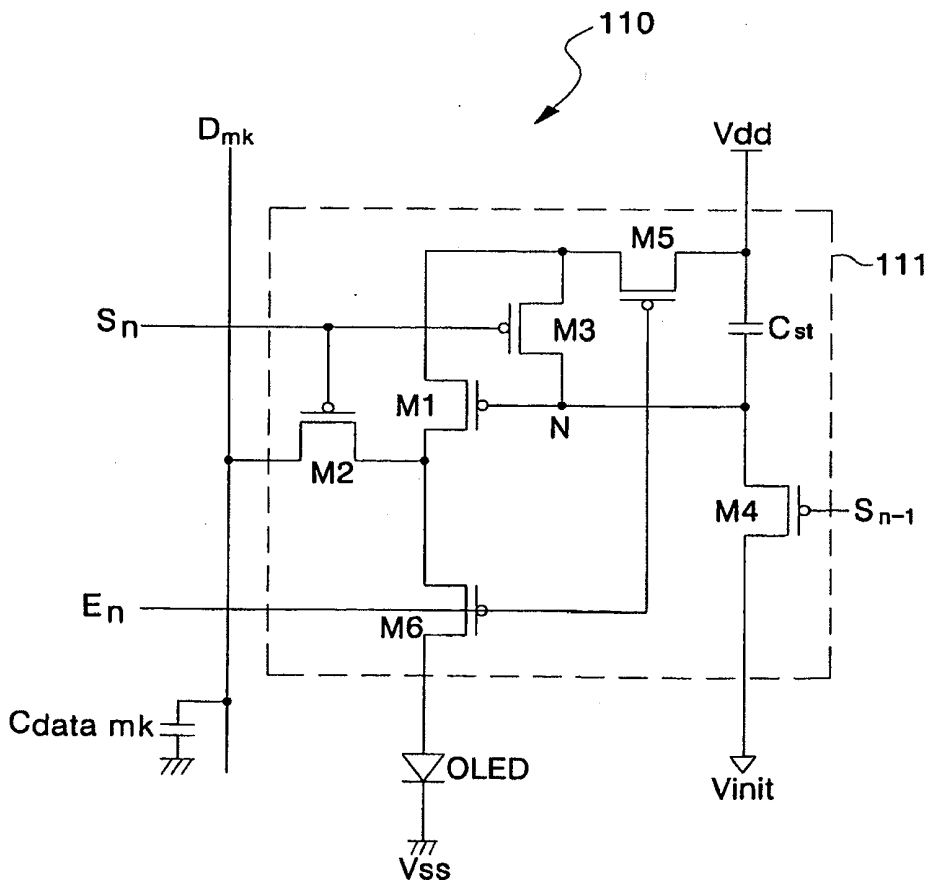

FIG. 5

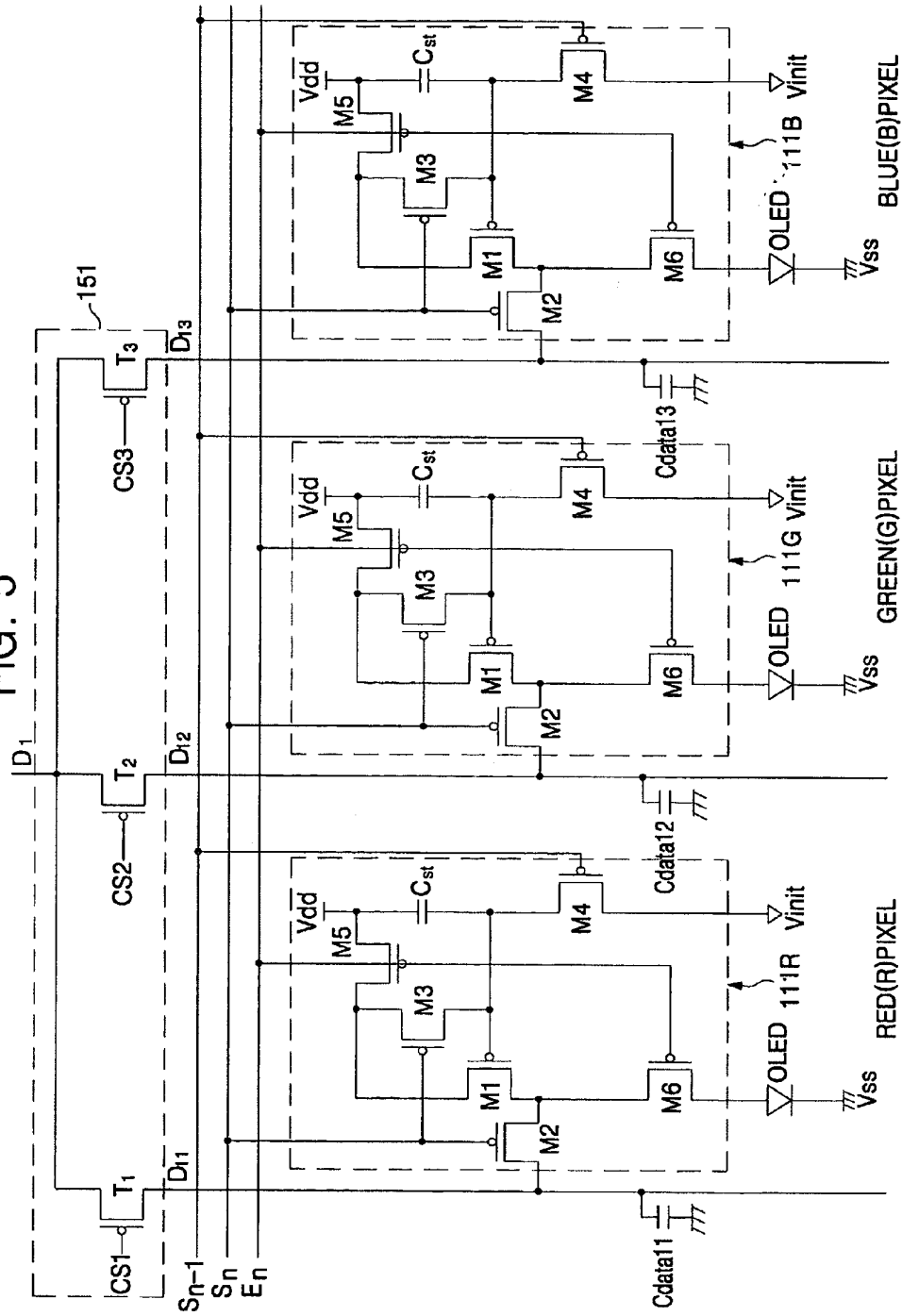

FIG. 6

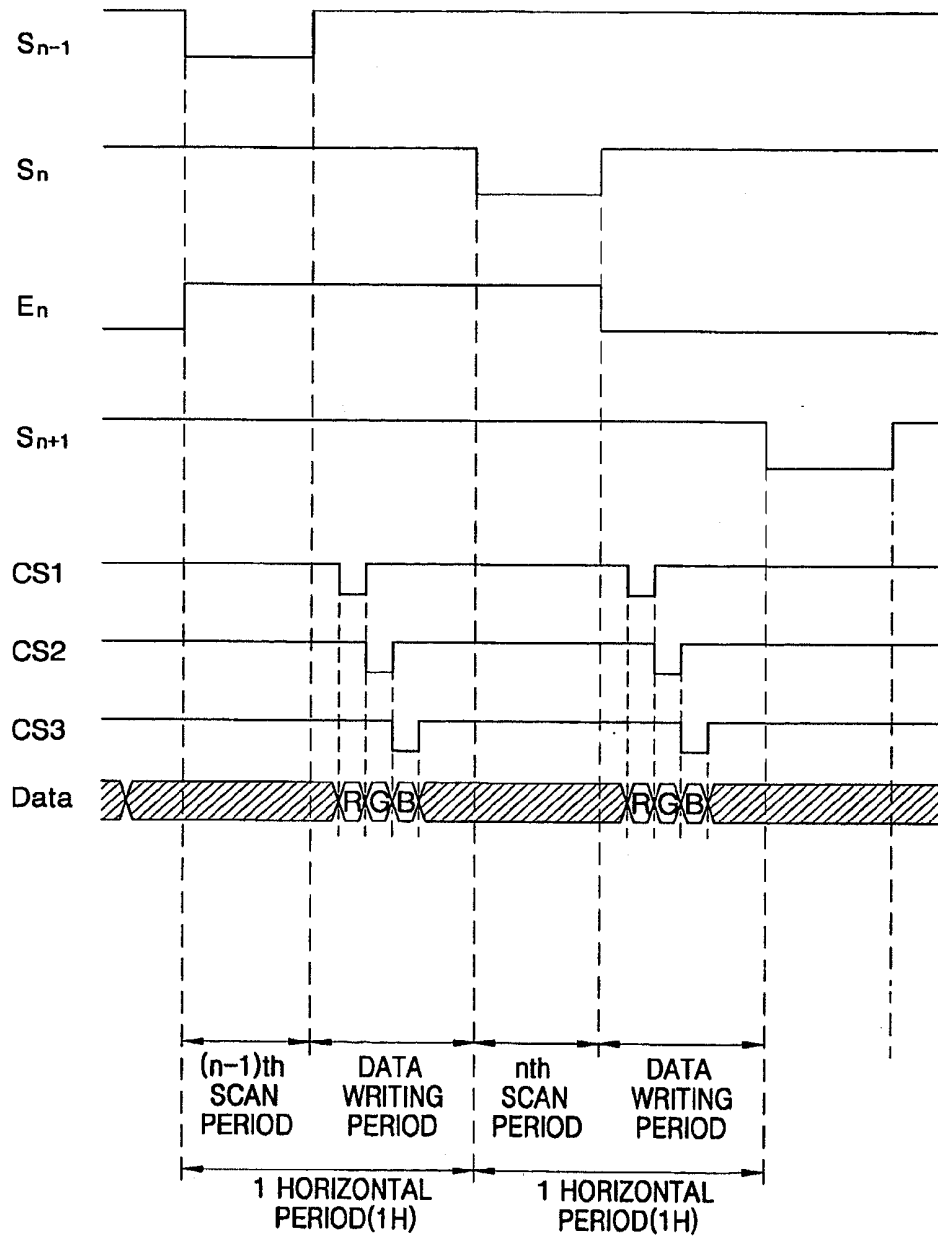

FIG. 7

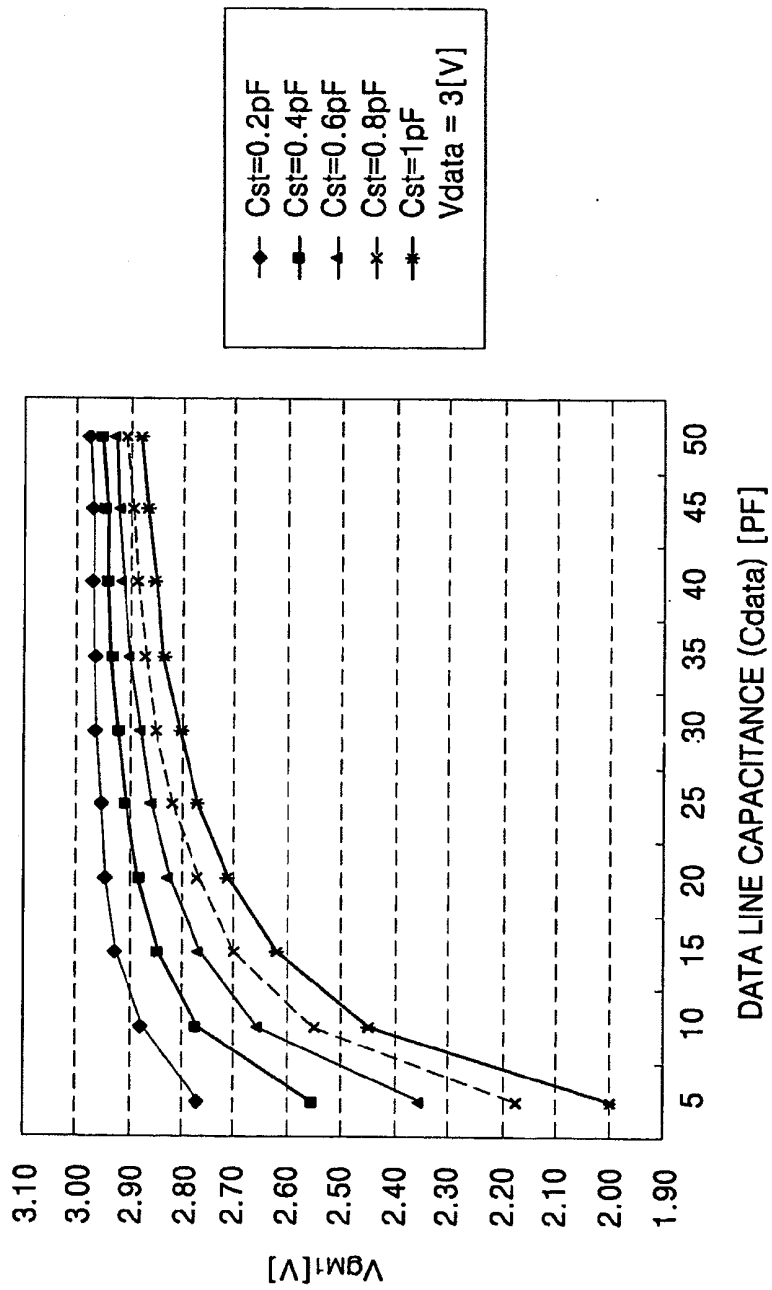

FIG. 8

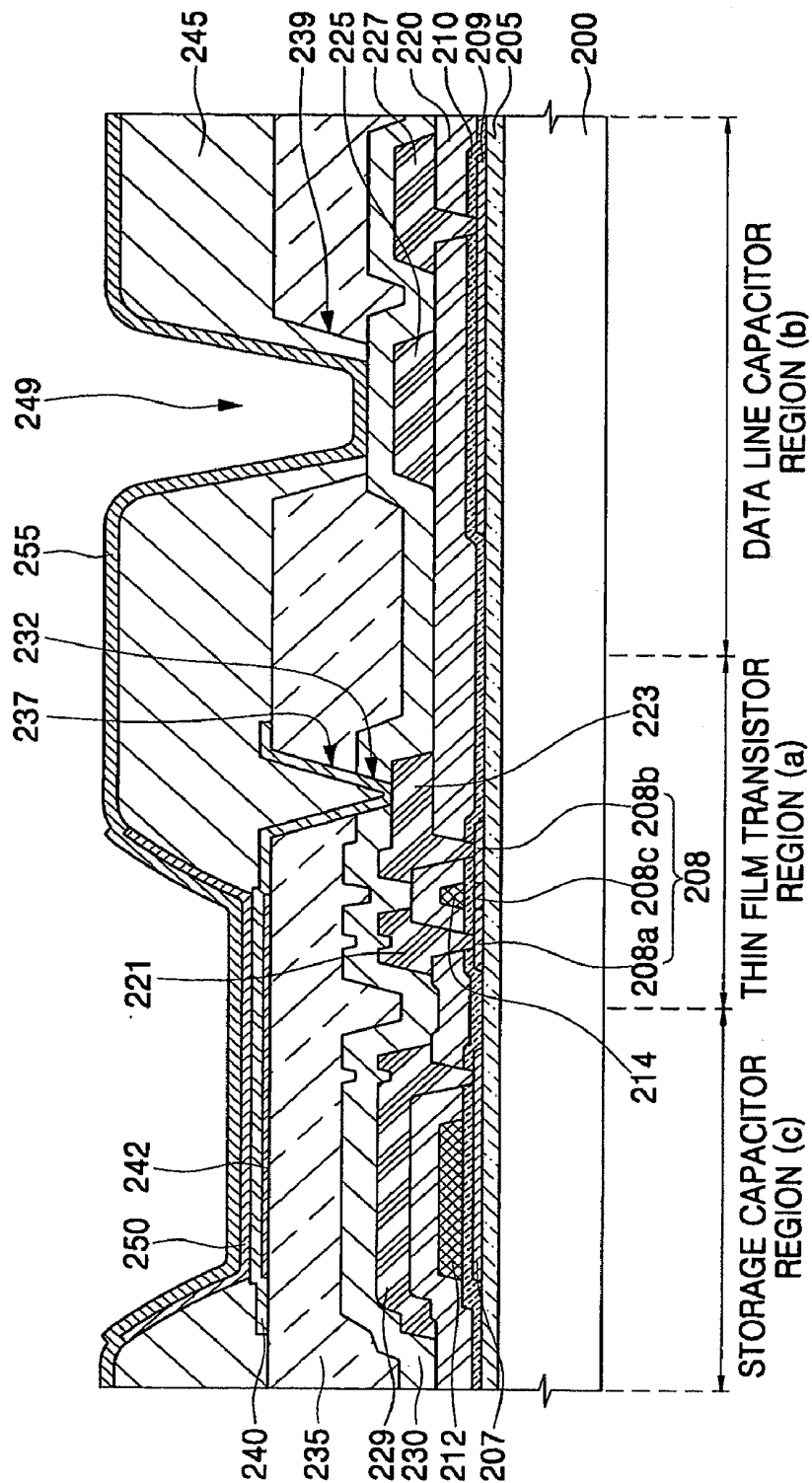

FIG. 9

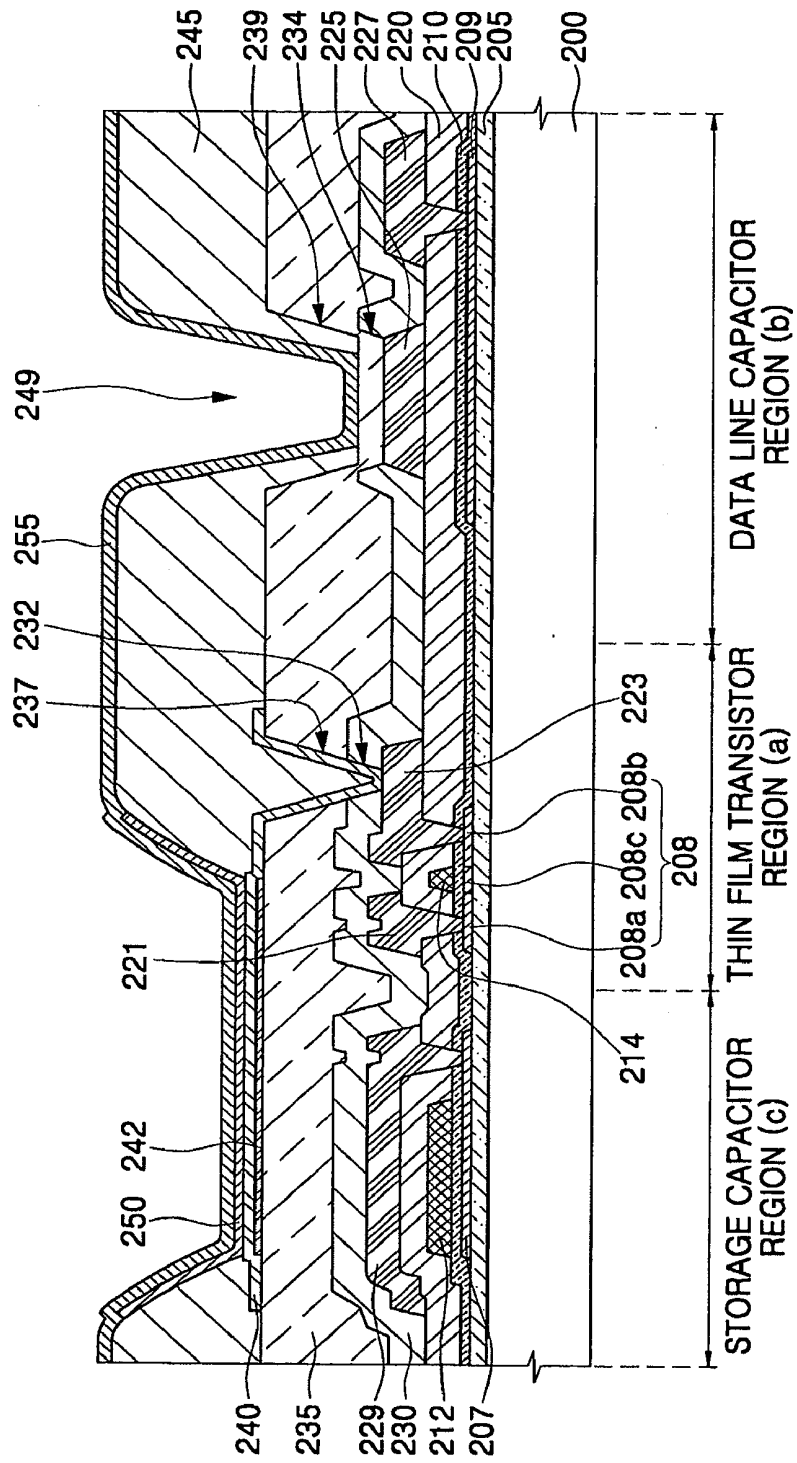

FIG. 10

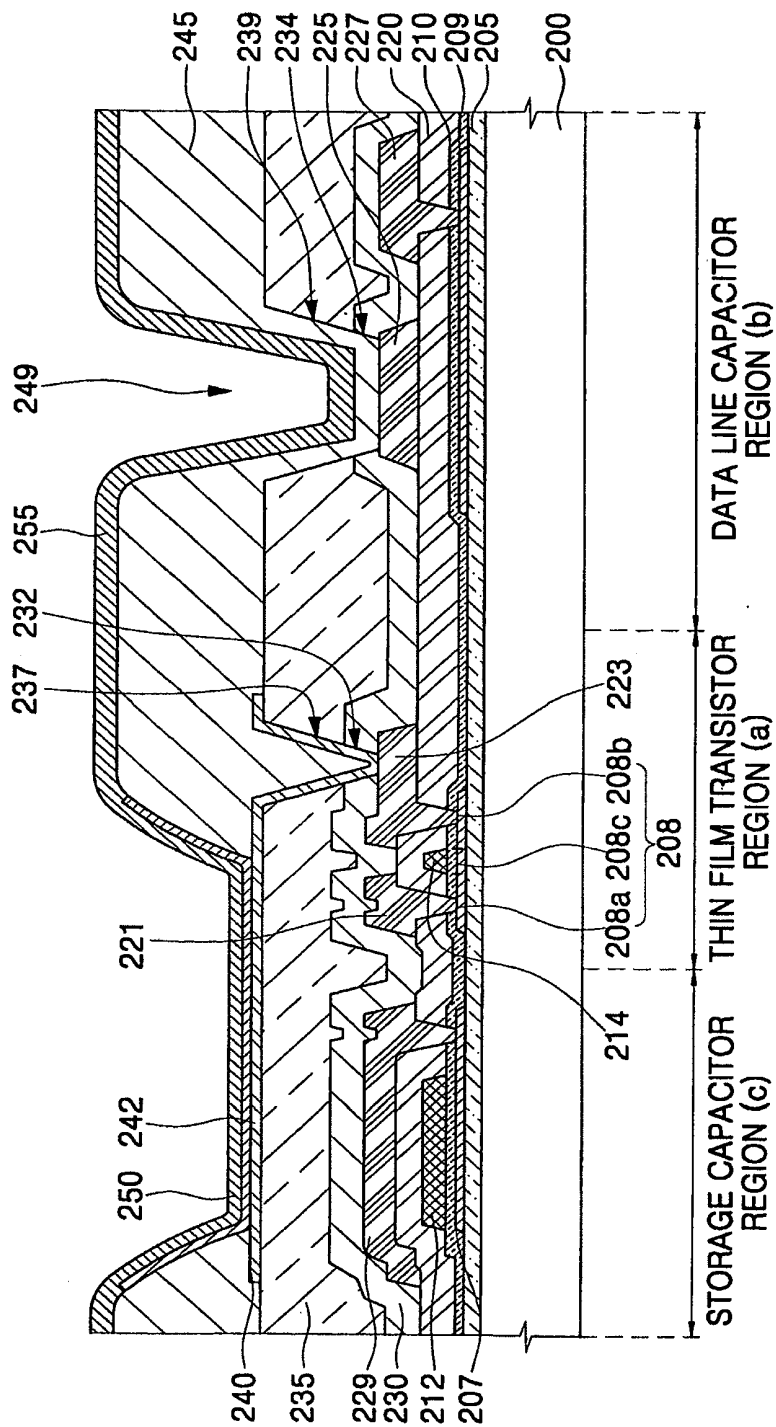

FIG. 11

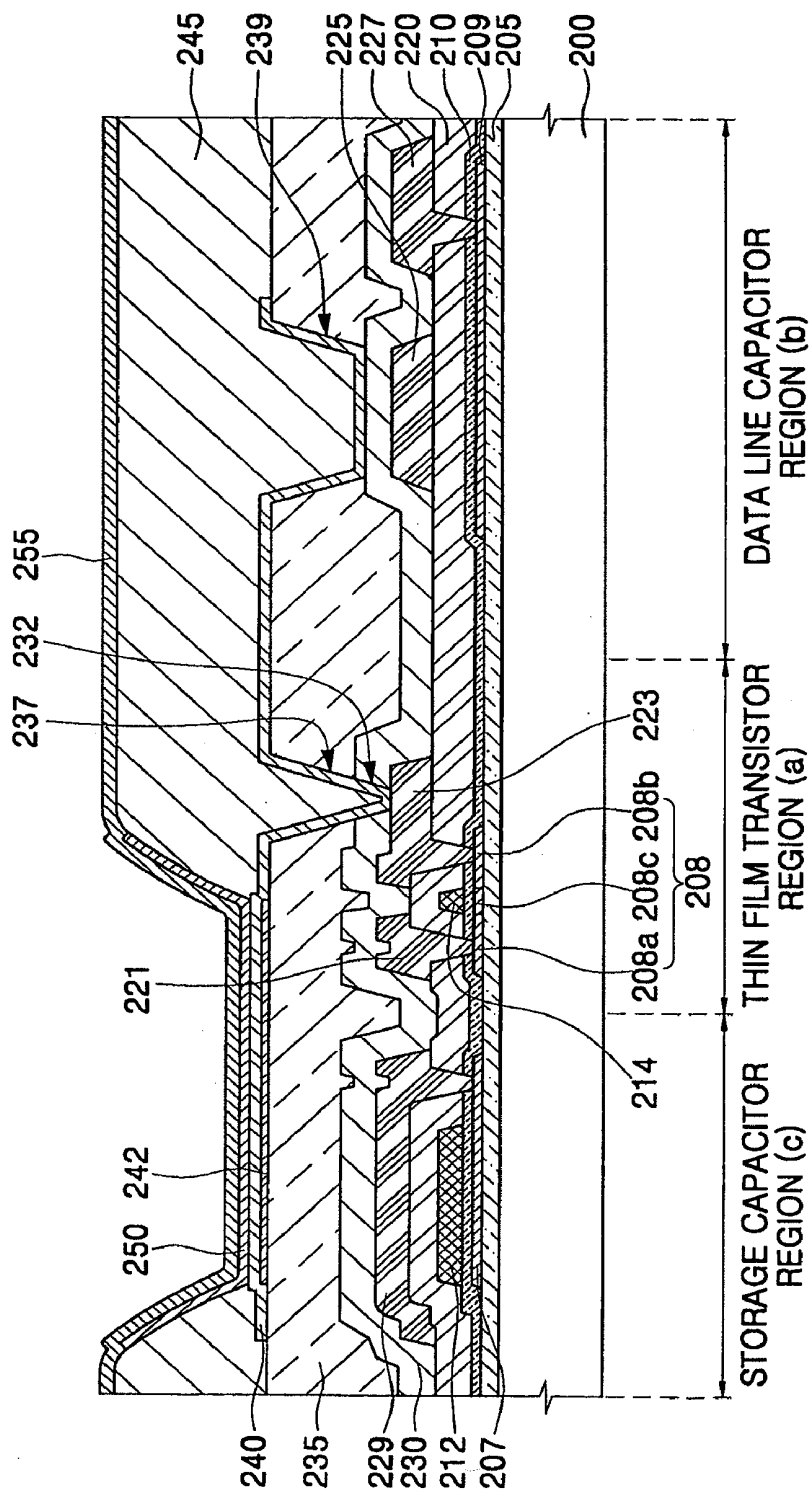

FIG. 12

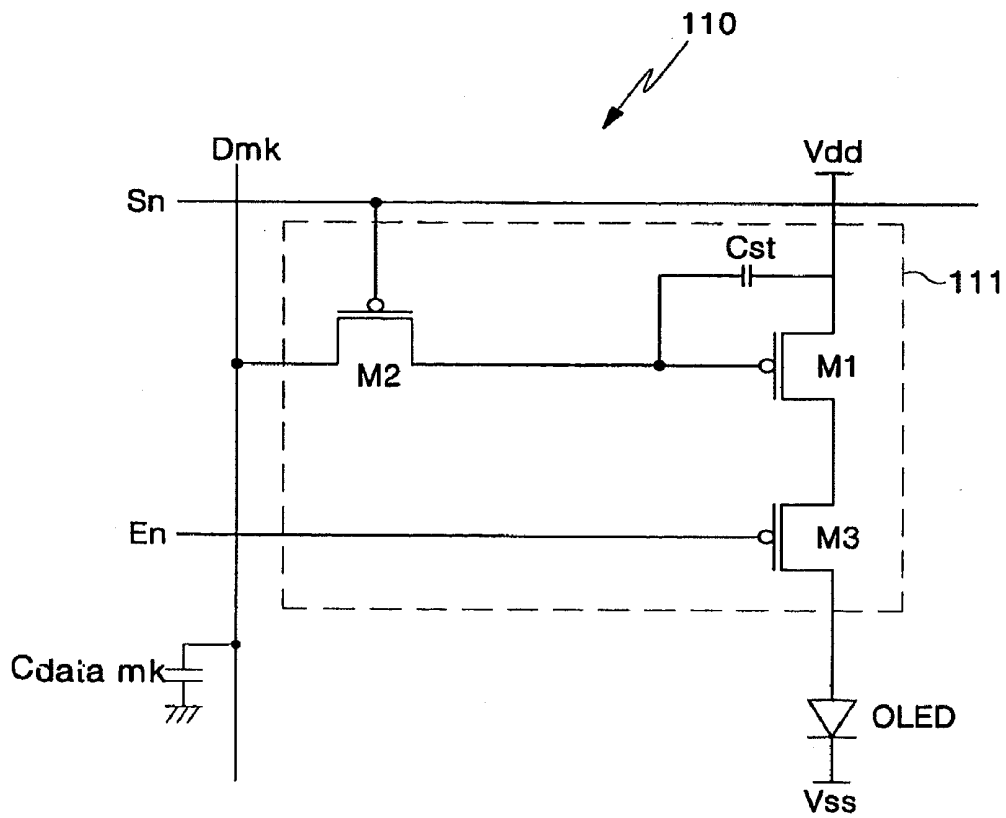

FIG. 13

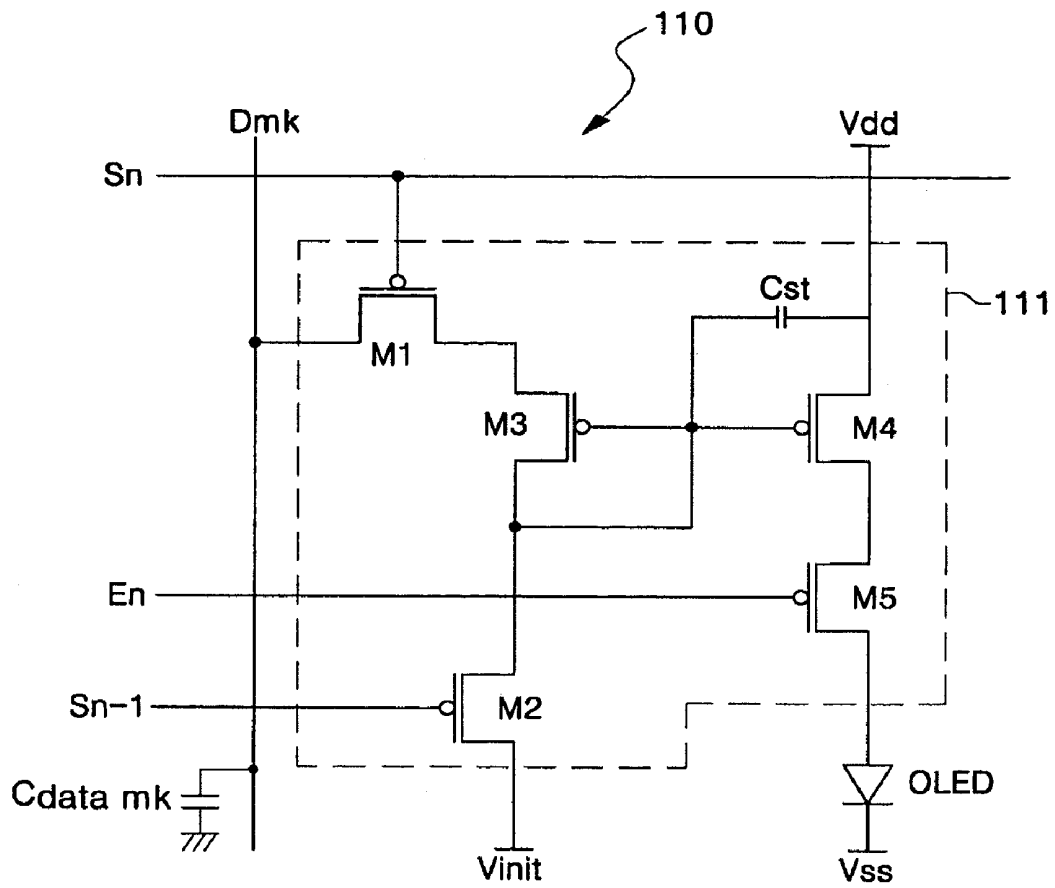
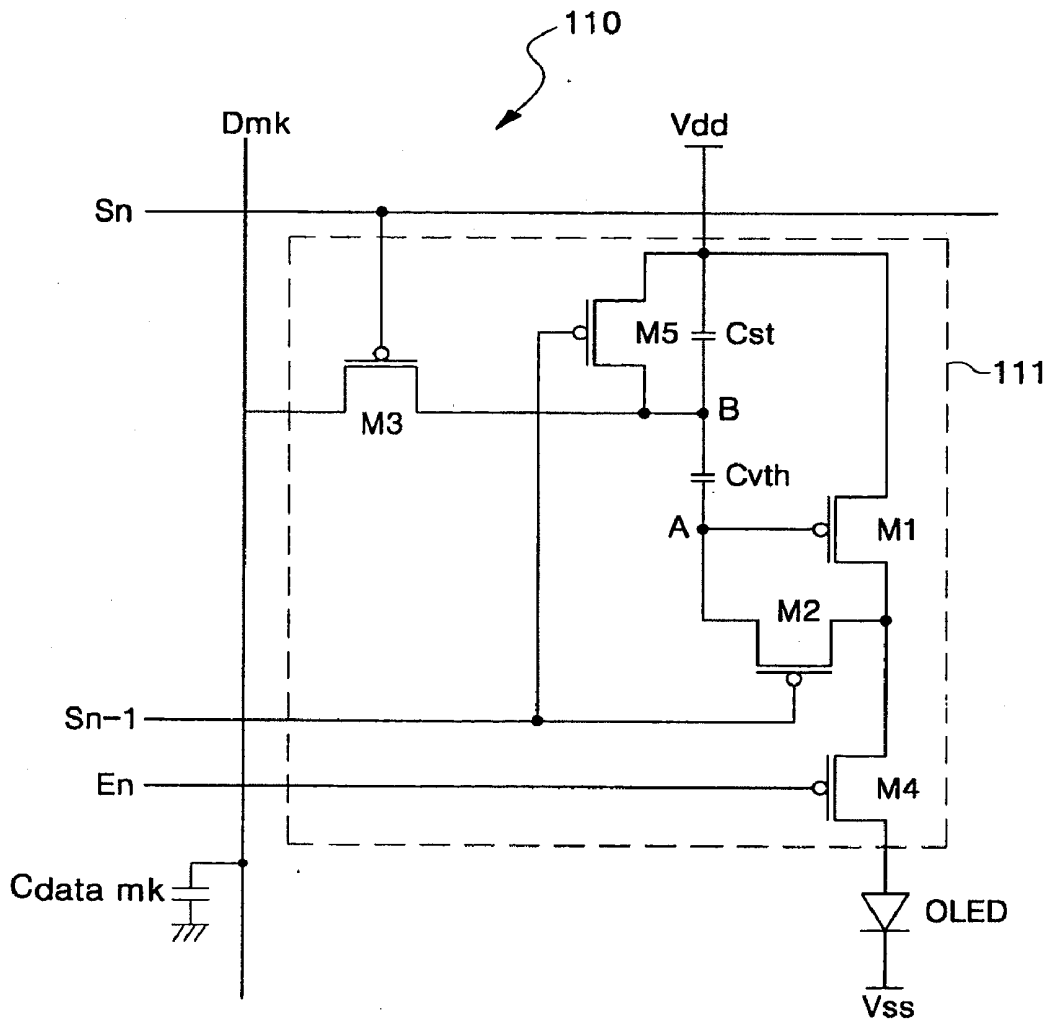

FIG. 14



ORGANIC LIGHT EMITTING DISPLAY

CROSS-REFERENCE TO RELATED APPLICATIONS

[0001] This application is a divisional of and claims priority to U.S. application Ser. No. 11/432,598, filed May 11, 2006, which claims priority to and the benefit of Korean Patent Application No. 10-2005-0039895, filed May 12, 2005, each of which is incorporated herein by reference in its entirety.

BACKGROUND OF THE INVENTION

[0002] 1. Field of the Invention

[0003] The present invention relates to an organic light emitting display (OLED), and more particularly, to an OLED that makes use of demultiplexers to decrease the number of output lines of data drivers and display an image having uniform luminance.

[0004] 2. Description of the Related Art

[0005] In recent years, a variety of flat panel displays (FPDs) with small weight and volume have been developed to overcome the drawbacks of a cathode ray tube (CRT). The FPDs can be categorized into a liquid crystal display (LCD), a field emission display (FED), a plasma display panel (PDP), an organic light emitting display (OLED), and the like.

[0006] An OLED includes an organic light emitting diode, which is a self-emissive display device that emits light through the recombination of electrons supplied from a cathode and holes supplied from an anode. The OLED has a high response speed of about 1 μ s and consumes low power. The OLED includes a plurality of pixels, each of which supplies a driving current corresponding to a data signal to the organic light emitting diode using a driving thin film transistor (TFT) so that the organic light emitting diode emits light to display a predetermined image.

[0007] FIG. 1 is a block diagram of a conventional OLED.

[0008] Referring to FIG. 1, the conventional OLED includes a display panel 10, a scan driver 20, a data driver 30, and a timing controller 40.

[0009] The display panel 10 includes a plurality of pixels P_{11} - P_{nm} , which are disposed in regions where a plurality of scan lines and emission control lines S_1 - S_n and E_1 - E_n intersect a plurality of data lines D_1 - D_m . Each of the pixels P_{11} - P_{nm} receives a first power supply Vdd and a second power supply Vss from external power supplies and emits light corresponding to a received data signal to display an image. Also, the pixels P_{11} - P_{nm} emit light for a time that is controlled according to a signal supplied through the emission control lines E_1 - E_n , respectively.

[0010] The scan driver 20 generates a scan signal in response to a scan control signal S_g received from the timing controller 40 and sequentially transmits the generated scan signal to the plurality of scan lines S_1 - S_n to select the pixels P_{11} - P_{nm} . Also, the scan driver 20 generates an emission control signal in response to the scan control signal S_g and sequentially transmits the generated emission control signal to the plurality of emission control lines E_1 - E_n to control the emission.

[0011] The data driver 30 receives red (R), green (G), and blue (B) data from the timing controller 40, generates data signals in response to a data control signal S_d , and transmits the generated data signals to the plurality of data lines D_1 - D_m . In this case, the data driver 30 transmits data signals corre-

sponding to one horizontal line for each horizontal period to the plurality of data lines D_1 - D_m .

[0012] The timing controller 40 generates data control signals S_d and scan control signals S_g corresponding to R, G, and B data supplied from an external graphic controller (not shown) and horizontal and vertical synchronous signals Hsync and Vsync. The data control signals S_d and the scan control signals S_g generated by the timing controller 40 are supplied to the data driver 30 and the scan driver 20, respectively.

[0013] In the conventional OLED having the above-described construction, the respective pixels P_{11} - P_{nm} are located in the regions where the scan lines and the emission control lines S_1 - S_n and E_1 - E_n intersect the data lines D_1 - D_m . Here, the data driver 30 includes m output lines such that it transmits data signals to each of the m data lines D_1 - D_m . In other words, the data driver 30 should include the output lines in a number equal to the number of the data lines D_1 - D_m . Accordingly, the data driver 30 should include a plurality of data integrated circuits (ICs) to install the m output lines, thus elevating the cost of production. In particular, as the display panel 10 increases in resolution and size, the data driver 30 should include more data ICs. Thus, the cost of production further increases.

SUMMARY OF THE INVENTION

[0014] The present invention, therefore, provides an organic light emitting display (OLED), which makes use of demultiplexers to decrease the number of data drivers and display an image having uniform luminance.

[0015] One embodiment comprises an organic light emitting display (OLED) including a display panel having a plurality of pixels disposed in regions where a plurality of scan lines intersect a plurality of data lines, a scan driver configured to supply scan signals to the scan lines so as to select the pixels, a plurality of demultiplexers configured to supply data signals to the data lines, a data driver configured to supply the data signals to a plurality of output lines connected to the demultiplexers, and a plurality of data line capacitors each disposed in one of the data lines and configured to store a voltage corresponding to the data signal.

[0016] Another embodiment comprises an organic light emitting display (OLED) including a substrate, a storage capacitor region, a thin film transistor region, and a data line capacitor region each formed on the substrate. The OLED also has a storage capacitor formed in the storage capacitor region, the storage capacitor including a first semiconductor layer formed on the substrate, a gate insulating layer formed on the first semiconductor layer, a first electrode formed on the gate insulating layer, an interlayer insulating layer formed on the first electrode, and a second electrode formed on the interlayer insulating layer, where the second electrode is electrically connected to the first semiconductor layer. The OLED also has a thin film transistor formed in the thin film transistor region, the thin film transistor including a second semiconductor layer formed on the substrate, a gate insulating layer formed on the second semiconductor layer. The OLED also has a gate electrode formed on the gate insulating layer, a source electrode formed on the gate insulating layer, and a drain electrode formed on the gate insulating layer, and a first data line capacitor formed in the data line capacitor region, the first data line capacitor including a third semiconductor layer formed on the substrate, a gate insulating layer formed on the third semiconductor layer, an interlayer insulating

layer formed on the gate insulating layer, and a data line formed on the interlayer insulating layer. The OLED also has an organic light emitting diode formed on the storage capacitor and the thin film transistor and including a pixel electrode connected to one of the source and drain electrodes, an organic emission layer formed on the pixel electrode, and an opposite electrode formed on the storage capacitor, the thin film transistor, and the first data line capacitor. The OLED also has a second data line capacitor formed on the data line capacitor, the second data line capacitor including the data line, an insulating layer formed over the data line, and the opposite electrode.

[0017] Another embodiment comprises an organic light emitting display (OLED) including a substrate, a storage capacitor region, a thin film transistor region, and a data line capacitor region each formed on the substrate. The OLED also has a storage capacitor formed in the storage capacitor region, the storage capacitor including a first semiconductor layer formed on the substrate, a gate insulating layer formed on the first semiconductor layer, a first electrode formed on the gate insulating layer, an interlayer insulating layer formed on the first electrode, and a second electrode formed on the interlayer insulating layer, where the second electrode is electrically connected to the first semiconductor layer. The OLED also has a thin film transistor formed in the thin film transistor region, the thin film transistor including a second semiconductor layer formed on the substrate, a gate insulating layer formed on the second semiconductor layer, a gate electrode formed on the gate insulating layer, a source electrode formed on the gate insulating layer, and a drain electrode formed on the gate insulating layer, and a first data line capacitor formed in the data line capacitor region, the first data line capacitor including a third semiconductor layer formed on the substrate, a gate insulating layer formed on the third semiconductor layer, an interlayer insulating layer formed on the gate insulating layer, and a data line formed on the interlayer insulating layer. The OLED also has an organic light emitting diode formed on the storage capacitor and the thin film transistor and including a pixel electrode connected to one of the source and drain electrodes, an organic emission layer formed on the pixel electrode, and an opposite electrode formed on the storage capacitor, the thin film transistor, and the first data line capacitor. The OLED also has a second data line capacitor formed on the data line capacitor, the second data line capacitor including the data line, an insulating layer formed over the data line, and the pixel electrode.

BRIEF DESCRIPTION OF THE DRAWINGS

[0018] The above and other features and advantages of certain inventive aspects are discussed with further detail with reference to the attached drawings in which:

- [0019] FIG. 1 is a block diagram of a conventional organic light emitting display (OLED);
 [0020] FIG. 2 is a block diagram of an OLED according to an exemplary embodiment;
 [0021] FIG. 3 is a circuit diagram of a demultiplexer shown in FIG. 2;
 [0022] FIG. 4 is a circuit diagram of one of $N \times M$ pixels shown in FIG. 2;
 [0023] FIG. 5 is a detailed circuit diagram showing connection of the demultiplexer to the pixels shown in FIG. 2;
 [0024] FIG. 6 is a timing diagram illustrating operations of the pixel circuit shown in FIG. 5;

[0025] FIG. 7 is a graph of simulation results showing gate voltages of a driving transistor versus capacitances of a data line capacitor and a storage capacitor of a pixel in the OLED;

[0026] FIG. 8 is a cross-sectional view of a pixel having a structure to increase the capacitance of a data line capacitor according to one embodiment;

[0027] FIG. 9 is a cross-sectional view of a pixel having a structure to increase the capacitance of a data line capacitor according to another embodiment;

[0028] FIG. 10 is a cross-sectional view of a pixel having a structure to increase the capacitance of a data line capacitor according to yet another embodiment;

[0029] FIG. 11 is a cross-sectional view of a pixel having a structure to increase the capacitance of a data line capacitor according to still another embodiment;

[0030] FIG. 12 is a circuit diagram of another pixel of the OLED shown in FIG. 2;

[0031] FIG. 13 is a circuit diagram of yet another pixel of the OLED shown in FIG. 2; and

[0032] FIG. 14 is a circuit diagram of still another pixel of the OLED shown in FIG. 2.

DETAILED DESCRIPTION OF THE INVENTION

[0033] FIG. 2 is a block diagram of an organic light emitting display (OLED) according to one embodiment of the present invention.

[0034] Referring to FIG. 2, the OLED includes a display panel 100, a scan driver 120, a data driver 130, a timing controller 140, a demultiplexer unit 150, and a demultiplexer controller 160.

[0035] The display panel 100 includes a plurality of pixels P_{111} - P_{nmk} and a plurality of data line capacitors C_{data11} - C_{datamk} . The pixels P_{111} - P_{nmk} are disposed in a region that comprises a plurality of scan lines and emission control lines S_1 - S_n and E_1 - E_n , and a plurality of data lines D_{11} - D_{mk} . Also, the data line capacitors C_{data11} - C_{datamk} are formed by the respective data lines D_{11} - D_{mk} .

[0036] Each of the pixels P_{111} - P_{nmk} emits light corresponding to a data signal applied from one of the data lines D_{11} - D_{mk} . A pixel 110, which is representative of the pixels P_{111} - P_{nmk} , will be described later.

[0037] Also, the plurality of data line capacitors C_{data11} - C_{datamk} are formed by each of the data lines D_{11} - D_{mk} in order to store the data signal temporarily. For example, the data line capacitor C_{data11} of the data line D_{11} is formed by connecting in parallel all of the data line capacitors $C_{data111}$, $C_{data211}$, \dots , and $C_{datan11}$, which are formed in the regions where the pixels P_{111} , P_{211} , \dots , and P_{n11} connect to the data line D_{11} . That is, it can be expressed that $C_{data11} = C_{data111} + C_{data211} + \dots + C_{datan11}$.

[0038] For example, during a data writing period, when a data signal is applied to the first data line D_{11} to make the first pixel P_{111} emit light, the data signal is temporarily stored in the first data line capacitor C_{data11} formed in the data line D_{11} . Next, during a scan period, once the first pixel P_{111} is selected by a first scan signal S_1 , the data voltage stored in the first data line capacitor C_{data11} is applied to the first pixel P_{111} so that the first pixel P_{111} emits light corresponding to the data voltage. In other words, the data line capacitors C_{data11} - C_{datamk} formed in each of the data lines D_{11} - D_{mk} temporarily store the data signal applied to the data lines D_{11} - D_{mk} and apply the stored data voltages to the pixels P_{111} - P_{nmk} selected by the appropriate scan signal. Here, the data line capacitors C_{data11} - C_{datamk} make use of parasitic capacitors that are formed by

the data lines D_{11} - D_{mk} , an electrode, and an insulating layer interposed therebetween. Actually, the capacitance of each of the data line capacitors C_{data11} - C_{datamk} that are equivalently formed in the data lines D_{11} - D_{mk} may be greater than the capacitance of a storage capacitor C_{st} included in each of the pixels P_{111} - P_{nmk} in order to stably store the data signal. In some embodiments, the data line capacitors C_{data11} - C_{datamk} have capacitance of about 20 pF to about 50 pF.

[0039] The scan driver **120** generates a scan signal in response to scan control signals S_g applied from the timing controller **140** and sequentially transmits the scan signal to the scan lines S_1 - S_n . Here, the scan driver **120** transmits the scan signal to each scan line only during a partial period (i.e., a scan period) of one horizontal period 1H as shown in FIG. 6. More specifically, one horizontal period 1H is divided into a scan period and a data writing period. The scan driver **120** transmits a scan signal to the scan line S during the scan period of the one horizontal period 1H but does not transmit the scan signal during the data writing period. Additionally, the scan driver **120** generates an emission control signal in response to the scan control signals S_g and sequentially transmits the emission control signal to the emission control lines E_1 - E_n to control the emission operation.

[0040] The data driver **130** receives R, G, and B data from the timing controller **140** and sequentially transmits R, G, B data signals to output lines D_1 - D_m in response to data control signals S_d . During the data writing period, the data driver **130** sequentially transmits k (k is an integral number equal to or more than 2) data signals (but, FIG. 6 illustrates only R, G, B data signals). More specifically, the data driver **130** sequentially transmits data signals (e.g., R, G, and B data), which will be supplied to corresponding pixels during a data writing period of the one horizontal period 1H. In this case, since the data signals R, G, and B, which will be supplied to the corresponding pixels, are supplied only during the data writing period, the data writing period does not overlap the scan period for which scan signals are supplied.

[0041] The timing controller **140** generates the data control signals S_d and the scan control signals S_g corresponding to R, G, and B data supplied from an external graphic controller (not shown) and horizontal and vertical synchronous signals. The data control signals S_d and the scan control signals S_g , which are generated by the timing controller **140**, are supplied to the data driver **130** and the scan driver **120**, respectively.

[0042] The demultiplexer unit **150** includes m demultiplexers **151**. Specifically, the demultiplexer unit **150** includes the demultiplexers **151** in a number equal to the number of the output lines D_1 - D_m connected to the data driver **130**. The demultiplexers **151** have input terminals connected to the output lines D_1 - D_m , respectively, and have output terminals connected to the $m \times k$ data lines D_{11} - D_{mk} . Each of the demultiplexers **151** drive k data signals, to the k data lines to which they are each connected. Because of the demultiplexers, the number of output lines included in the data driver **130** is sharply reduced. For example, assuming that k is 3, the number of output lines included in the data driver **130** is reduced to about $\frac{1}{3}$ as many as in the conventional case, thus the number of data integrated circuits (ICs) included in the data driver **130** is also reduced. In the present invention, the data signals, which are supplied to one output line D_i , are supplied to the k data lines D_{11} - D_{1k} using the demultiplexers **151**, so that the fabrication cost of the data ICs can be greatly reduced.

[0043] The demultiplexer controller **160** transmits k control signals to control terminals of the demultiplexers **151**,

during the data writing period of the one horizontal period 1H, such that the k data signals are each driven onto the correct data line of the k data lines D_{11} - D_{1k} . In this case, the k data signals, which are supplied from the demultiplexer controller **160**, are sequentially supplied so as to not overlap one another during the data writing period as shown in FIG. 6. Meanwhile, although it is illustrated in FIG. 2 that the demultiplexer controller **160** is installed separate from the timing controller **140**, in other embodiments the demultiplexer controller **160** may be integrated with the timing controller **140**.

[0044] FIG. 3 is a circuit diagram of an embodiment of one of the demultiplexers shown in FIG. 2.

[0045] In the embodiment of FIG. 3, k is 3 for. Also, the demultiplexer shown in FIG. 3 is connected to the first output line D_1 of the data driver **130**.

[0046] Referring to FIG. 3, the demultiplexer **151** includes a first switching device T_1 , a second switching device T_2 , and a third switching device T_3 . Each of the switching devices T_1 , T_2 , and T_3 may be formed of a thin film transistor (TFT). In this embodiment, each of the switching devices T_1 , T_2 , and T_3 is formed of a p-type metal oxide semiconductor field effect transistor (MOSFET), however, in other embodiments they may be formed of an n-type MOSFET, or another type of switching element.

[0047] The first switching device T_1 is connected between the first output line D_1 and the first data line D_{11} . The first switching device T_1 is turned on when a first control signal CS1 is supplied from the demultiplexer controller **160** and transmits the data signal, which is supplied from the first output line D_1 , to the first data line D_{11} . The data signal supplied to the first data line D_1 is stored in the first data line capacitor C_{data11} during the data writing period as described above with reference to FIG. 2.

[0048] The second switching device T_2 is connected between the first output line D_1 and the second data line D_{12} . The second switching device T_2 is turned on when a second control signal CS2 is supplied from the demultiplexer controller **160** and transmits the data signal, which is supplied from the first output line D_1 , to the second data line D_{12} . The data signal supplied to the second data line D_{12} is stored in the second data line capacitor C_{data12} during the data writing period as described above with reference to FIG. 2.

[0049] The third switching device T_3 is connected between the first output line D_1 and the third data line D_{13} . The third switching device T_3 is turned on when a third control signal CS3 is supplied from the demultiplexer controller **160** and transmits the data signal, which is supplied from the first output line D_1 , to the third data line D_{13} . The data signal supplied to the third data line D_{13} is stored in the third data line capacitor C_{data13} during the data writing period as described above with reference to FIG. 2. The operations of the demultiplexers **151** will be described in detail later along with the construction of the pixel **110**.

[0050] FIG. 4 is a circuit diagram of one of the $n \times m \times k$ pixels shown in FIG. 2. Here, a pixel according to an one embodiment is shown, but other pixels may also be used.

[0051] Referring to FIG. 4, the pixel **110** includes an organic light emitting diode OLED and a pixel driving circuit **111**, which is connected to a data line D_{mk} , scan lines S_n and S_{n-1} , an emission control line E_n , a first voltage line Vdd, and an initialization voltage line V_{init} and generates a driving current for the organic light emitting diode OLED. A data line capacitor $C_{data\ mk}$ is formed in the data line D_{mk} to store a data voltage for the pixel **110**.

[0052] The organic light emitting diode OLED has an anode connected to the pixel driving circuit 111 and a cathode connected to a second power supply line Vss. A second power supply Vss may be a voltage lower than a first power supply Vdd, for example, a ground or negative (-) voltage. The organic light emitting diode OLED emits light corresponding to the driving current supplied from the pixel driving circuit 111.

[0053] The pixel driving circuit 111 includes a storage capacitor C_{st} and six transistors M1-M6. Here, the first transistor M1 is a driving transistor, the third transistor M3 is a threshold voltage compensation transistor for diode-connecting the first transistor M1 to compensate for a threshold voltage, and the fourth transistor M4 is an initialization transistor for initializing the storage capacitor C_{st} . Also, the sixth transistor M6 is an emission control transistor for controlling the emission of the organic light emitting diode OLED, and the second and fifth transistors M2 and M5 are switching transistors.

[0054] The second switching transistor M2 has a gate electrode connected to an nth scan line S_n and a source electrode connected to the data line D_{mk} . The second switching transistor M2 is turned on in response to a scan signal transmitted through the nth scan line S_n and transmits a data voltage applied from the data line capacitor $C_{data\ mk}$.

[0055] The driving transistor M1 has a source electrode connected to a drain electrode of the second switching transistor M2 and a gate electrode connected to a node N. A source or drain electrode of the threshold voltage compensation transistor M3 and a first terminal of the storage capacitor C_{st} are also connected to the node N, so that a gate voltage of the driving transistor M1 is the same as voltage of the node N. Thus, the driving transistor M1 generates a driving current corresponding to the voltage applied to its gate electrode.

[0056] The threshold voltage compensation transistor M3 is connected between the gate and source electrodes of the driving transistor M1 and diode-connects the driving transistor M1 in response to the scan signal transmitted through the nth scan line S_n . Thus, the driving transistor M1 functions as a diode in response to the scan signal so that a voltage $V_{data-Vth}$ is applied to the node N and becomes the gate voltage of the driving transistor M1.

[0057] The initialization transistor M4 is connected between the initialization power supply line Vinit and the first terminal of the storage capacitor C_{st} . The initialization transistor M4 discharges electric charges, which are charged in the storage capacitor C_{st} during the previous frame period, through the initialization power supply line Vinit in response to a scan signal supplied through the (n-1)th scan line S_{n-1} connected to the gate electrode, so that the storage capacitor C_{st} can be initialized.

[0058] The fifth switching transistor M5 is connected between the first power supply line Vdd and the source electrode of the driving transistor M1. The fifth switching transistor M5 is turned on in response to an emission control signal supplied through the nth emission control line E_n , connected to the gate electrode and supplies the first power supply Vdd to the source electrode of the driving transistor M1.

[0059] The emission control transistor M6 is connected between the driving transistor M1 and the organic light emitting diode OLED. The emission control transistor M6 transmits the driving current, which is generated by the driving transistor M1, to the organic light emitting diode OLED in

response to an emission control signal supplied through the nth emission control line E_n , connected to the gate electrode.

[0060] The storage capacitor C_{st} is connected between the first power supply line Vdd and the gate electrode of the driving transistor M1. The storage capacitor C_{st} maintains electric charges so as to maintain a voltage difference between the first power supply Vdd and the voltage $V_{data-Vth}$ applied to the gate electrode of the driving transistor M1, during one frame period.

[0061] Although it is illustrated in FIG. 4 that each of the transistors M1-M6 is a p-type MOSFET, each of the transistors M1-M6 can instead be designed as an N-type MOSFET.

[0062] FIG. 5 is a detailed circuit diagram showing the connection of the demultiplexer with the pixels shown in FIG. 2, and FIG. 6 is a timing diagram illustrating operations of a pixel circuit shown in FIG. 5. Here, red (R), green (G), and blue (B) pixels are connected to the demultiplexers 151 which is connected to the first output line D1 (i.e., k=3).

[0063] Referring to FIGS. 5 and 6, a low-level scan signal is applied to the (n-1)th scan line S_{n-1} during an (n-1)th scan period of one horizontal period 1H. Once the scan signal applied to the (n-1)th scan line S_{n-1} , the initialization transistor M4, which is included in each of the R, G, and B pixels, is turned on. When the initialization transistor M4 is turned on, one terminal of the storage capacitor C_{st} and a gate terminal of the driving transistor M1 are connected to the initialization power supply line Vinit. That is, when the scan signal is applied to the (n-1)th scan line S_{n-1} , a data voltage of the previous frame stored in the storage capacitor C_{st} of each of the R, G, and B pixels, i.e., the gate voltage of the driving transistor M1, is initialized. When the scan signal is applied to the (n-1)th scan line S_{n-1} , the first switching transistor M2 connected to the nth scan line S_n remains turned off.

[0064] Thereafter, the first switching device T_1 , the second switching device T_2 , and the third switching device T_3 are sequentially turned on in response to the first through third control signals CS1, CS2, and CS3 that are sequentially supplied during the data writing period. Initially, when the first switching device T_1 is turned on in response to the first control signal CS1, an R data signal supplied to the first output line D1 is applied to the first data line D_{11} . In this case, the first data line capacitor C_{data11} is charged with a voltage corresponding to the R data signal applied to the first data line D_{11} . Next, the second switching device T_2 is turned on in response to the second control signal CS2, thus a G data signal supplied to the first output line D1 is applied to the second data line D_{12} . In this case, the second data line capacitor C_{data12} is charged with a voltage corresponding to the G data signal applied to the second data line D_{12} . Finally, the third switching device T_3 is turned on in response to the third control signal CS3, thus a B data signal supplied to the first output line D1 is applied to the third data line D_{13} . In this case, the third data line capacitor C_{data13} is charged with a voltage corresponding to the B data signal applied to the third data line D_{13} . Meanwhile, since no scan signal is applied to the nth scan line S_n during the data writing period, the R, G, and B data signals are not supplied to the R, G, and B pixels.

[0065] Thereafter, a low-level scan signal is applied to the nth scan line S_n during an nth scan period that follows the data writing period. Once the scan signal is applied to the nth scan line S_n , the first switching transistor M2 and the threshold voltage compensation transistor M3 which are included in each of the R, G, and B pixels are turned on. The first switching transistor M2 of each of the R, G, and B pixels transmits

a voltage V_{data} corresponding to the R, G, and B data signals, which are stored in the first through third data line capacitors C_{data11} - C_{data13} in the data writing period, to the R, G, and B pixels. The threshold voltage compensation transistor M3 serves to diode-connect the driving transistor M1. That is, a voltage $V_{data}-V_{th_{M1}}$ [V] corresponding to a difference between the voltage V_{data} corresponding to the R, G, and B data signals stored in the first through third data line capacitors C_{data11} - C_{data13} and a threshold voltage V_{th} of the driving transistor M1 is applied to the gate terminal of the driving transistor M1 and one terminal of the storage capacitor C_{st} through the diode-connected driving transistor M1.

[0066] Thereafter, a low-level emission control signal is applied to the emission control line En. Thus, both the fifth switching transistor M5 and the emission control transistor M6 are turned on, so that a driving current corresponding to the first power supply Vdd applied to the source terminal of the driving transistor M1 and the voltage $V_{data}-V_{th_{M1}}$ applied to its gate terminal is supplied to the organic light emitting diode OLED through the emission control transistor M6. Thus, the organic light emitting diode OLED emits light with a luminance corresponding to the data.

[0067] In this case, the driving current supplied to the organic light emitting diode OLED can be expressed as Equation 1:

$$\frac{I_{OLED}}{V_{th_{M1}}^2} = \frac{K(V_{gs_{M1}} - V_{th_{M1}})^2}{K(V_{dd} - V_{data} + V_{th_{M1}} - V_{th_{M1}})^2} = K(V_{dd} - V_{data} + V_{th_{M1}} - V_{th_{M1}})^2 \quad (1)$$

where I_{OLED} is the current that flows through the organic light emitting diode OLED, $V_{gs_{M1}}$ is the voltage between the source and gate electrodes of the first transistor M1, $V_{th_{M1}}$ is the threshold voltage of the first transistor M1, V_{data} is the data voltage, V_{dd} is the first voltage, and K is a constant.

[0068] As can be seen from Equation 1, the driving current corresponding to the first power supply voltage Vdd and the R, G, and B data voltages V_{data} stored in the data line capacitors C_{data11} , C_{data12} , and C_{data13} of an the data lines D11, D12, and D13 flows through the organic light emitting diode OLED irrespective of the threshold voltage $V_{th_{M1}}$ of the driving transistor M1. In other words, a pixel according to an exemplary embodiment of the present invention detects a variance of the threshold voltage $V_{th_{M1}}$ of the driving transistor M1 using the threshold voltage compensation transistor M3 and compensates for the variance on its own, thereby improving the non-uniformity of luminance resulting from the variance of the threshold voltage $V_{th_{M1}}$.

[0069] Accordingly, the OLED is advantageous in supplying R, G, and B data signals, which are sequentially applied to the first output line D1, to the k data lines D_{11} - D_{1k} using the demultiplexers 151. Also, voltages corresponding to data signals are stored in the data line capacitors C_{data11} - C_{data1k} during the data writing period, and the voltages stored in the data line capacitors C_{data11} - C_{data1k} are applied to pixels during the scan period. Since the voltages stored in the data line capacitors C_{data11} - C_{data1k} are simultaneously applied to the respective pixels, i.e., since the respective data signals are supplied at the same point in time, an image with uniform luminance can be displayed.

[0070] However, as one horizontal period 1H is divided into the scan period and the data writing period, the data line capacitor C_{data1k} and the storage capacitor C_{st} included in each of the pixels, which are separated during the data writing period, are connected to each other during the scan period. Thus, electric charges equivalent to the data voltage V_{data} stored in the data line capacitor C_{data1k} are shared between

the capacitors C_{data1k} and C_{st} , so that the gate voltage $V_{g_{M1}}$ of the driving transistor M1 is substantially given by.

$$V_{g_{M1}} = \frac{C_{data}V_{data} + C_{st}(V_{init} - V_{dd})}{(C_{data} + C_{st})} \quad (2)$$

where $V_{g_{M1}}$ is the gate voltage of the driving transistor M1, V_{data} is the data voltage, V_{init} is the initialization voltage, V_{dd} is the first power supply, C_{data} is the data line capacitor, and C_{st} the storage capacitor included in each of the pixels.

[0071] As can be seen from Equation 2, there may be a difference between the gate voltage $V_{g_{M1}}$ of the driving transistor M1 and the data voltage V_{data} applied according to the capacitances of the data line capacitor C_{data} and the storage capacitor C_{st} included in each of the pixels. Because of the difference between the applied data voltage V_{data} and the gate voltage $V_{g_{M1}}$, the luminance of the OLED may become non-uniform.

[0072] FIG. 7 is a graph of simulation results showing gate voltages of a driving transistor versus capacitances of a data line capacitor and a storage capacitor of a pixel. In FIG. 7, it is assumed that the data voltage V_{data} applied to each pixel of FIG. 5 is 3 [V].

[0073] Referring to FIG. 7, the simulation results were obtained by measuring the gate voltage $V_{g_{M1}}$ of the driving transistor M1 while setting the capacitance of the storage capacitor C_{st} included in the pixel to 0.2, 0.4, 0.6, 0.8, and 1 [PF] and varying the capacitance of the data line capacitor C_{data} from 5 to 50 [PF].

[0074] In applying a data voltage V_{data} of 3[V] to the data line, when the capacitance of the data line capacitor C_{data} was 5 [PF], the gate voltage $V_{g_{M1}}$ of the driving transistor M1 was 2, 2.35, and 2.75[V] when the capacitance of the storage capacitor C_{st} included in the pixel was 1, 0.6, and 0.2 [PF], respectively.

[0075] However, as the capacitance of the data line capacitor C_{data} was increased to 20 [PF], the gate voltage $V_{g_{M1}}$ of the driving transistor M1 was 2.7, 2.85, and 2.94[V] when the capacitance of the storage capacitor C_{st} included in the pixel was 1, 0.6, and 0.2 [PF], respectively. That is, the gate voltage $V_{g_{M1}}$ of the driving transistor M1 was generally increased higher than when the capacitance of the data line capacitor C_{data} was 5 [PF].

[0076] Also, as the capacitance of the data line capacitor C_{data} was increased to 50 [PF], the gate voltage $V_{g_{M1}}$ of the driving transistor M1 was 2.89, 2.93, and 2.98[V] when the capacitance of the storage capacitor C_{st} included in the pixel was 1, 0.6, and 0.2 [PF], respectively. That is, the gate voltage $V_{g_{M1}}$ of the driving transistor M1 was generally increased higher than when the capacitance of the data line capacitor C_{data} was 20 [PF]. Accordingly, based on the simulation results of FIG. 7, it can be concluded that when the data line capacitor C_{data} has much greater capacitance than the storage capacitor C_{st} of the pixel, the gate voltage $V_{g_{M1}}$ of the driving transistor M1 is equal or close to the applied data voltage V_{data} . That is, in the pixel to which the data voltage V_{data} is applied using the demultiplexer of FIG. 5 according to the timing diagram of FIG. 6, the capacitance of the data line capacitor C_{data} may be about 20 to 50 [PF]. In this case, the applied data voltage V_{data} becomes almost equal to the gate voltage $V_{g_{M1}}$ of the driving transistor M1 so that the OLED has uniform luminance.

[0077] Processes of fabricating pixels for substantially elevating the capacitance of the data line capacitor C_{data} to 20 to 50 [PF] will now be described with reference to cross-sectional views of FIGS. 8 through 11.

[0078] FIG. 8 is a cross-sectional view of a pixel having a structure to increase the capacitance of a data line capacitor according to one embodiment. In FIG. 8, a pixel region is divided into 3 regions, i.e., a TFT region (a), a data line capacitor region (b), and a storage capacitor region (c). The TFT region (a) supplies a driving current to an organic light emitting diode. The data line capacitor region (b) receives a data voltage during the data writing period and temporarily stores the data voltage. Also, the storage capacitor region (c) stores the data voltage for a predetermined time during an nth scan period.

[0079] Referring to FIG. 8, a substrate 200 is prepared to form the pixel region according to one embodiment. The substrate 200 may be a transparent or opaque substrate. Also, the substrate 200 may comprise at least one of glass, plastic, quartz, silicon and metal.

[0080] A buffer layer 205 may be formed on the substrate 200. The buffer layer 205 may comprise at least one of a silicon oxide (SiO_2) layer, a silicon nitride (SiN_x) layer, a silicon oxynitride (SiO_2N_x) layer, and a multi-layer thereof.

[0081] First through third semiconductor layers 207, 208, and 209 are patterned on the buffer layer 205. That is, the first semiconductor layer 207 is patterned in the storage capacitor region (c), the second semiconductor layer 208 is patterned in the TFT region (a), and the third semiconductor layer 209 is patterned in the data line capacitor region (b). The first through third semiconductor layers 207, 208, and 209 may be amorphous silicon (a-Si) layers or polysilicon silicon (poly-Si) layers obtained by crystallizing the a-Si layers. In some embodiments, the first through third semiconductor layers 207, 208, and 209 are poly-Si layers having high charge mobility.

[0082] A gate insulating layer 210 is formed over the entire surface of the substrate 200 including the first through third semiconductor layers 207, 208, and 209. The gate insulating layer 210 may comprise at least one of a silicon oxide (SiO_2) layer, a silicon nitride (SiN_x) layer, a silicon oxynitride (SiO_2N_x) layer, and a multi-layer thereof.

[0083] A first electrode 212 of a storage capacitor C_{st} is formed on the gate insulating layer 210 in the storage capacitor region (c) to overlap the first semiconductor layer 207, and a gate electrode 214 is formed on the TFT region (a) to overlap the second semiconductor layer 208. In this case, while the first electrode 212 and the gate electrode 214 are being formed, scan lines (S_{n-1} , S_n , and E_n of FIG. 4) can be formed at the same time.

[0084] Thereafter, dopants (n^+ or p^+ type) are implanted into the second semiconductor layer 208 in the TFT region (a) using the gate electrode 214 as a mask. Thus, source and drain regions 208a and 208b are formed in regions that do not overlap the gate electrode 214 formed on the second semiconductor layer 208. In this case, a channel region 208c is defined between the source and drain regions 208a and 208b.

[0085] An interlayer insulating layer 220 is formed over the entire surface of the substrate 200 including the first electrode 212 and the gate electrode 214. Contact holes are formed in the interlayer insulating layer 220 and the gate insulating layer 210 to expose the first through third semiconductor layers 207, 208, and 209. A conductive layer is formed on the substrate 200 including the contact holes and then patterned,

thereby forming source and drain electrodes 221 and 223 in the TFT region (a). Then, a data line 225 and a metal 227 which applies a reference voltage to the third semiconductor layer 209, are formed in the data line capacitor region (b). Also, a second electrode 229, which comes into contact with the first semiconductor layer 207, is formed in the storage capacitor region (c).

[0086] Here, the second semiconductor layer 208, the gate insulating layer 210, the gate electrode 214, the source electrode 221, and the drain electrode 223 are formed in the TFT region (a) to produce a TFT. The TFT may be, for example, a driving transistor (M1 of FIG. 4), which generates a driving current, or an emission control transistor (M6 of FIG. 4), which supplies the driving current to the organic light emitting diode OLED.

[0087] Also, the first semiconductor layer 207, the gate insulating layer 210, the first electrode 212, the interlayer insulating layer 220, and the second electrode 229 which is in contact with the first semiconductor layer 207, are formed in the storage capacitor region (c) to produce a storage capacitor C_{st} .

[0088] Further, the third semiconductor layer 209, the gate insulating layer 210, the interlayer insulating layer 220, the data line 225 are formed in the data line capacitor region (b) to produce a first data line capacitor C_{data1} .

[0089] A passivation layer 230 is formed over the entire surface of the substrate 200 including the electrodes 221, 223, 225, 227, and 229 that are formed by patterning the conductive layer. The passivation layer 230 may comprise at least one of a silicon oxide (SiO_2) layer, a silicon nitride (SiN_x) layer, and a multi-layer thereof. In some embodiments the passivation layer 230 is formed of a silicon nitride (SiN_x) layer, which effectively protects the underlying TFT from gas or moisture and may be hydrogen-rich to protect incomplete bonding existing in grain boundaries of the poly-Si layer.

[0090] A first via hole 232 is formed in the passivation layer 230 to expose the drain electrode 223 of the TFT.

[0091] A planarization layer 235 is formed on the passivation layer 230 to reduce the step height, and may comprise at least one of an organic layer, such as a benzocyclobutene (BCB) layer, a polyimide layer, and a polyacryl layer.

[0092] A second via hole 237 and a third via hole 239 are formed in the planarization layer 235. The second via hole 237 exposes the drain electrode 223 of the TFT in the TFT region (a), and the third via hole 239 exposes the passivation layer 230 formed on the data line 225 in the data line capacitor region (b).

[0093] A pixel electrode 240 is formed on the planarization layer 235 having the second via hole 237 in the storage capacitor region (c) and the TFT region (a). The pixel electrode 240 is in contact with the drain electrode 223 that is exposed by the second via hole 237 in the TFT region (a). Also, since the pixel shown in FIG. 8 is a top-emitting type, the pixel electrode 240 may be formed of a light-reflecting conductive layer. The light-reflecting conductive layer may comprise at least one of Ag, Al, Ni, Pt, Pd, and an alloy thereof having a high work function. The light-reflecting conductive layer may comprise at least one of Mg, Ca, Al, Ag, Ba, or an alloy thereof having a low work function. In some embodiments, before the pixel electrode 240 is formed, a reflective layer pattern 242 may be further formed, and then the pixel electrode 240 may be formed thereon using a light-transmitting conductive layer. The light-transmitting conductive layer may comprise at least one of an indium tin oxide (ITO) and

indium zinc oxide (IZO) layer. In some embodiments the reflective layer pattern **242** has a reflectivity of 60% or higher and comprises at least one of Al, an Al alloy, Ag, an Ag alloy, and an alloy thereof. This reflective layer pattern **242** may be formed spaced apart from the second via hole **237** by a pre-determined distance.

[0094] A pixel defining layer (PDL) **245** is formed over the entire surface of the substrate **200** including the pixel electrode **240**. The PDL **245** may comprise at least one of BCB, acrylic photoresist, phenolic photoresist, and imidic photoresist.

[0095] An opening **247** and a fourth via hole **249** are formed in the PDL **245**. The opening **247** exposes at least a portion (emission region) of the pixel electrode **240** and the fifth via hole **249** exposes the passivation layer **230** formed on the data line **225** in the data line capacitor region (b).

[0096] An organic emission layer **250** is formed on the region of the pixel electrode **240** that is exposed by the opening. The organic emission layer **250** may be formed by a vacuum deposition process, an inkjet printing process, or a laser induced thermal imaging (LITI) process. Further, a hole injection layer, a hole transport layer, a hole blocking layer, an electron transport layer, or an electron injection layer may be formed on or under the organic emission layer **250**. Subsequently, an opposite electrode **255** is formed on the entire surface of the substrate **200** including the organic emission layer **250** and the PDL **245**. The opposite electrode **255** may comprise at least one of a light-transmitting conductive layer and a metal reflective layer. The light-transmitting conductive layer may be an ITO or IZO layer or formed of Mg, Ca, Al, Ag, Ba, or an alloy thereof to such a small thickness as to transmit light.

[0097] In the storage capacitor region (c) and the TFT region (a), the pixel electrode **240**, the organic emission layer **250**, and the opposite electrode **255** constitute an organic light emitting diode OLED. Also, the data line **225**, the passivation layer **230**, and the opposite electrode **255** form a second data line capacitor C_{data2} in the data line capacitor region (b).

[0098] While the organic light emitting diode operates, holes and electrons (or electrons and holes) are emitted from the pixel electrode **240** and the opposite electrode **255**, respectively, and injected into the organic emission layer **250**. The holes and electrons combine with each other in the organic emission layer **250**, thus generating excitons. As the excitons are changed from an excited state to a ground state, the organic emission layer **250** emits light. The light emitted from the organic emission layer **250** is reflected by the pixel electrode **240** formed of a light-reflecting conductive layer or the reflective layer pattern **242** disposed under the pixel electrode **240** formed of a light-transmitting conductive layer, and passes through the opposite electrode **255** formed of the light-transmitting layer to be emitted to the exterior.

[0099] As described above, the pixel according one embodiment includes the first data line capacitor C_{data1} obtained by forming the third semiconductor layer **209** under the data line **225**. Also, the planarization layer **235** and the PDL **245** are etched through the third and/or fourth via holes **239** and/or **249** in the data line capacitor region (b), so that the opposite electrode **255** and the data line **225** form the second data line capacitor C_{data2} using only the passivation layer **230** as a dielectric layer.

[0100] Accordingly, the data line capacitor C_{data} has a structure to which the first and second data line capacitors C_{data1} and C_{data2} are connected in parallel about the data line

225. That is, $C_{data} = C_{data1} + C_{data2}$. In applying the pixel structure according to one embodiment, the data line capacitor C_{data} has a capacitance of 20 to 50 [PF], which is about 16 times more than in the conventional pixel structure. Therefore, when the pixel driving method using the demultiplexers is applied according that described above, the gate voltage Vg of the driving transistor becomes substantially equal to the applied data voltage Vdata, so that the OLED can display improved gray scale and have substantially uniform luminance.

[0101] The capacitance of the data line capacitor C_{data} may be adjusted by controlling the size of a via hole formed in an insulating layer, such as a passivation layer, a planarization layer, or a PDL and the size of a contact hole via which a semiconductor layer is in contact with a metal.

[0102] FIG. 9 is a cross-sectional view of a pixel having a structure to increase the capacitance of a data line capacitor according to another embodiment. In FIG. 9, a pixel region is divided into 3 regions, i.e., a TFT region (a), a data line capacitor region (b), and a storage capacitor region (c) like in FIG. 8. Here, the same processes as described with reference to FIG. 8 will be briefly described, but different processes will be described in detail.

[0103] Referring to FIG. 9, a substrate **200** is prepared to form a pixel region. A buffer layer **205** may be formed on the substrate **200**.

[0104] First through third semiconductor layers **207**, **208**, and **209** are patterned over the buffer layer **205**. That is, the first semiconductor layer **207** is patterned in the storage capacitor region (c), the second semiconductor layer **208** is patterned in the TFT region (a), and the third semiconductor layer **209** is patterned in the data line capacitor region (b).

[0105] A gate insulating layer **210** is formed over the entire surface of the substrate **200** including the first through third semiconductor layers **207**, **208**, and **209**. The gate insulating layer **210** may comprise at least one of a silicon oxide (SiO_2) layer, a silicon nitride (SiN_x) layer, a silicon oxynitride (SiO_2N_x) layer, and a multi-layer thereof.

[0106] A first electrode **212** of a storage capacitor C_{st} is formed on the gate insulating layer **210** in the storage capacitor region (c) to overlap the first semiconductor layer **207**, and a gate electrode **214** is formed in the TFT region (a) to overlap the second semiconductor layer **208**. In this case, while the first electrode **212** and the gate electrode **214** are being formed, scan lines (S_{n-1} , S_n , and E_n of FIG. 4) may also be formed at the same time.

[0107] Thereafter, dopants (n^+ or p^+ type) are implanted into the second semiconductor layer **208** in the TFT region (a) using the gate electrode **214** as a mask. Thus, source and drain regions **208a** and **208b** are formed in regions that do not overlap the gate electrode **214** formed on the second semiconductor layer **208**. In this case, a channel region **208c** is defined between the source and drain regions **208a** and **208b**.

[0108] An interlayer insulating layer **220** is formed over the entire surface of the substrate **200** including the first electrode **212** and the gate electrode **214**. Contact holes are formed in the interlayer insulating layer **220** and the gate insulating layer **210** to expose the first through third semiconductor layers **207**, **208**, and **209**. A conductive layer is formed over the substrate **200** including the contact holes and then patterned, thereby forming source and drain electrodes **221** and **223** in the TFT region (a). Then, a data line **225** and a metal **227**, which applies a reference voltage to the third semiconductor layer **209**, are formed in the data line capacitor region

(b). Also, a second electrode **229**, which comes into contact with the first semiconductor layer **207**, is formed in the storage capacitor region (c).

[0109] Here, the second semiconductor layer **208**, the gate insulating layer **210**, the gate electrode **214**, the source electrode **221**, and the drain electrode **223** are formed in the TFT region (a) to produce a TFT. The TFT may, for example be a driving transistor (M1 of FIG. 4), which generates a driving current, or an emission control transistor (M6 of FIG. 4), which supplies the driving current to the organic light emitting diode OLED.

[0110] Also, the first semiconductor layer **207**, the gate insulating layer **210**, the first electrode **212**, the interlayer insulating layer **220**, and the second electrode **229** which is in contact with the first semiconductor layer **207**, are formed in the storage capacitor region (c) to form a storage capacitor C_{st} .

[0111] Further, the third semiconductor layer **209**, the gate insulating layer **210**, the interlayer insulating layer **220**, the data line **225** are stacked in the data line capacitor region (b) to form a first data line capacitor C_{data1} .

[0112] A passivation layer **230** is formed over the entire surface of the substrate **200** including the electrodes **221**, **223**, **225**, **227**, and **229** that are formed by patterning the conductive layer. The passivation layer **230** may comprise at least one of a silicon oxide (SiO_2) layer, a silicon nitride (SiN_x) layer, and a multi-layer thereof. Also, in some embodiments the passivation layer **230** may not be formed.

[0113] A first via hole **232** and a second via hole **234** are formed in the passivation layer **230**. The first via hole **232** exposes the drain electrode **223** of the TFT, and the second via hole **234** exposes the data line **225**.

[0114] A planarization layer **235** is formed on the passivation layer **230** to reduce the step height, and may be formed of an organic layer. A third via hole **237** is formed in the planarization layer **235** in the TFT region (a) to expose the drain electrode **223** in a region where the first via hole **232** is formed. Also, a fourth via hole **239** is formed in the planarization layer **235** formed on the data line **225**.

[0115] A pixel electrode **240** is formed on the planarization layer **235** having the third via hole **237** in the storage capacitor region (c) and the TFT region (a). The pixel electrode **240** is in contact with the drain electrode **223** that is exposed by the third via hole **237** in the TFT region (a). Additionally, since the pixel shown in FIG. 9 is a top-emitting type, the pixel electrode **240** may be formed of a light-reflecting conductive layer. In another embodiment, before the pixel electrode **240** is formed, a reflective layer pattern **242** may be further formed, and then the pixel electrode **240** may be formed using a light-transmitting conductive layer. This reflective layer pattern **242** may be spaced apart from the third via hole **237** by a predetermined distance.

[0116] A PDL **245** is formed on the entire surface of the substrate **200** including the pixel electrode **240**. An opening **247** and a fifth via hole **249** are formed in the PDL **245**. The opening **247** exposes at least a portion (emission region) of the pixel electrode **240**, and the fifth via hole **249** exposes the partially etched planarization layer **235** on the data line **225**.

[0117] An organic emission layer **250** is formed on the pixel electrode **240** that is exposed by the opening **247**. Subsequently, an opposite electrode **255** is formed on the entire surface of the substrate **200** including the organic emission

layer **250** and the PDL **245**. The opposite electrode **255** may comprise at least one of a light-transmitting conductive layer and a metal reflective layer.

[0118] In the storage capacitor region (c) and the TFT region (a), the pixel electrode **240**, the organic emission layer **250**, and the opposite electrode **255** form an organic light emitting diode. Also, the data line **225**, the planarization layer **235**, and the opposite electrode **255** form a second data line capacitor C_{data2} in the data line capacitor region (b).

[0119] As described above, in the pixel according to one embodiment, the first data line capacitor C_{data1} is produced by forming the third semiconductor layer **209** under the data line **225**. Also, the passivation layer **230**, the planarization layer **235**, and the PDL **245** are etched through the second, fourth, and fifth via holes **234**, **239** and **249** in the data line capacitor region (b), so that the opposite electrode **255** and the data line **225** constitute the second data line capacitor C_{data2} using only the planarization layer **235** as a dielectric layer.

[0120] Accordingly, the data line capacitor C_{data} has a structure to which the first and second data line capacitors C_{data1} and C_{data2} are connected in parallel about the data line **225**. That is, $C_{data} = C_{data1} + C_{data2}$. In applying the pixel structure according to the second embodiment of the present invention, the data line capacitor C_{data} has a capacitance of 20 to 50 [PF], which is about 16 times more than in the conventional pixel structure. Therefore, when the pixel driving method using the demultiplexers is used, the gate voltage V_g of a driving transistor becomes substantially equal to the applied data voltage V_{data} , so that the OLED can display exact gray scale and have uniform luminance.

[0121] The capacitance of the data line capacitor C_{data} may be adjusted by controlling the size of a via hole formed in an insulating layer, such as a passivation layer, a planarization layer, or a PDL and the size of a contact hole via which a semiconductor layer is in contact with a metal layer.

[0122] FIG. 10 is a cross-sectional view of a pixel having a structure to increase the capacitance of a data line capacitor according to yet another embodiment. In FIG. 10, a pixel region is divided into 3 regions, i.e., a TFT region (a), a data line capacitor region (b), and a storage capacitor region (c) like in FIG. 8. Here, the same processes as described with reference to FIG. 8 will be briefly described, but different processes will be described in detail.

[0123] Referring to FIG. 10, to form a pixel region according to this embodiment, a substrate **200** is prepared. A buffer layer **205** may be formed on the substrate **200**.

[0124] First through third semiconductor layers **207**, **208**, and **209** are patterned over the buffer layer **205**. That is, the first semiconductor layer **207** is patterned in the storage capacitor region (c), the second semiconductor layer **208** is patterned in the TFT region (a), and the third semiconductor layer **209** is patterned in the data line capacitor region (b).

[0125] A gate insulating layer **210** is formed on the entire surface of the substrate **200** including the first through third semiconductor layers **207**, **208**, and **209**. The gate insulating layer **210** may comprise at least one of a silicon oxide (SiO_2) layer, a silicon nitride (SiN_x) layer, a silicon oxynitride (SiO_2N_x) layer, and a multi-layer thereof.

[0126] A first electrode **212** of a storage capacitor C_{st} is formed on the gate insulating layer **210** in the storage capacitor region (c) to overlap the first semiconductor layer **207**, and a gate electrode **214** is formed in the TFT region (a) to overlap the second semiconductor layer **208**. In this case, while the

first electrode **212** and the gate electrode **214** are being formed, scan lines (S_{n-1} , S_n , and E_n of FIG. 4) may be formed at the same time.

[0127] Thereafter, dopants (n^+ or p^+ type) are implanted into the second semiconductor layer **208** in the TFT region (a) using the gate electrode **214** as a mask. Thus, source and drain regions **208a** and **208b** are formed in regions that do not overlap the gate electrode **214** formed on the second semiconductor layer **208**. In this case, a channel region **208c** is defined between the source and drain regions **208a** and **208b**.

[0128] An interlayer insulating layer **220** is formed over the entire surface of the substrate **200** including the first electrode **212** and the gate electrode **214**. Contact holes are formed in the interlayer insulating layer **220** and the gate insulating layer **210** to expose the first through third semiconductor layers **207**, **208**, and **209**. A conductive layer is formed over the substrate **200** including the contact holes and then patterned, thereby forming source and drain electrodes **221** and **223** in the TFT region (a). Then, a data line **225** and a metal **227**, which applies a reference voltage to the third semiconductor layer **209**, are formed in the data line capacitor region (b). Also, a second electrode **229**, which comes into contact with the first semiconductor layer **207**, is formed in the storage capacitor region (c).

[0129] Here, the second semiconductor layer **208**, the gate insulating layer **210**, the gate electrode **214**, the source electrode **221**, and the drain electrode **223** are stacked in the TFT region (a) to form a TFT. The TFT may, for example, be a driving transistor (M1 of FIG. 4), which generates a driving current, or an emission control transistor (M6 of FIG. 4), which supplies the driving current to the organic light emitting diode OLED. Also, the first semiconductor layer **207**, the gate insulating layer **210**, the first electrode **212**, the interlayer insulating layer **220**, and the second electrode **229**, which is in contact with the first semiconductor layer **207**, are formed such that they overlap in the storage capacitor region (c) to form a storage capacitor C_{st} . Further, the third semiconductor layer **209**, the gate insulating layer **210**, the interlayer insulating layer **220**, the data line **225** are formed such that they overlap in the data line capacitor region (b) to form a first data line capacitor C_{data1} .

[0130] A passivation layer **230** is formed over the entire surface of the substrate **200** including the electrodes **221**, **223**, **225**, **227**, and **229** that are formed by patterning the conductive layer. The passivation layer **230** may comprise at least one of a silicon oxide (SiO_2) layer, a silicon nitride (SiN_x) layer, and a multi-layer thereof. Also, in some embodiments the passivation layer **230** may not be formed. A first via hole **232** and a second via hole **234** are formed in the passivation layer **230**. The first via hole **232** exposes the drain electrode **223** of the TFT, and the second via hole **234** exposes the data line **225**.

[0131] A planarization layer **235** is formed on the passivation layer **230** to reduce the step height, and may be formed of an organic layer, such as a BCB layer, a polyimide layer, or a polyacryl layer. A third via hole **237** is formed in the planarization layer **235** in the TFT region (a) to expose the drain electrode **223** in a region where the first via hole **232** is formed. Also, a fourth via hole **239** is formed to expose the data line **225**.

[0132] A pixel electrode **240** is formed on the planarization layer **235** having the third via hole **237** in the storage capacitor region (c) and the TFT region (a). The pixel electrode **240** is in contact with the drain electrode **223** that is exposed by the

third via hole **237** in the TFT region (a). Additionally, since the pixel shown in FIG. 10 is a top-emitting type, the pixel electrode **240** may be formed of a light-reflecting conductive layer. In another embodiment, before the pixel electrode **240** is formed, a reflective layer pattern **242** may be further formed, and then the pixel electrode **240** may be formed using a light-transmitting conductive layer. This reflective layer pattern **242** may be spaced apart from the third via hole **237** by a predetermined distance.

[0133] A PDL **245** is formed on the entire surface of the substrate **200** including the pixel electrode **240**. An opening **247** and a fifth via hole **249** are formed in the PDL **245**. The opening **247** exposes at least a portion (emission region) of the pixel electrode **240**, and a portion of the PDL **245** is etched by the fifth via hole **249** on the data line **225**.

[0134] An organic emission layer **250** is formed on the pixel electrode **240** that is exposed by the opening **247**. Subsequently, an opposite electrode **255** is formed on the entire surface of the substrate **200** including the organic emission layer **250** and the PDL **245**. The opposite electrode **255** may comprise at least one of a light-transmitting conductive layer and a metal reflective layer.

[0135] In the storage capacitor region (c) and the TFT region (a), the pixel electrode **240**, the organic emission layer **250**, and the opposite electrode **255** form an organic light emitting diode. Also, the data line **225**, the planarization layer **235**, and the opposite electrode **255** form a second data line capacitor C_{data2} in the data line capacitor region (b).

[0136] As described above, the pixel according to one embodiment, the first data line capacitor C_{data1} is produced by forming the third semiconductor layer **209** under the data line **225**. Also, the passivation layer **230**, the planarization layer **235**, and the PDL **245** are etched through the second, fourth, and fifth via holes **234**, **239** and **249** in the data line capacitor region (b), and the opposite electrode **255** and the data line **225** constitute the second data line capacitor C_{data2} using only the PDL **245** as a dielectric layer.

[0137] Accordingly, the data line capacitor C_{data} has a structure to which the first and second data line capacitors C_{data1} and C_{data2} are connected in parallel about the data line **225**. That is, $C_{data} = C_{data1} + C_{data2}$. In applying the pixel structure according to the third embodiment of the present invention, the data line capacitor C_{data} has a capacitance of 20 to 50 [PF], which is about 16 times more than in the conventional pixel structure. Therefore, when the pixel driving method using the demultiplexers is used, the gate voltage V_g of a driving transistor becomes substantially equal to the applied data voltage V_{data} , so that the OLED can display exact gray scale and have uniform luminance.

[0138] The capacitance of the data line capacitor C_{data} may be adjusted by controlling the size of a via hole formed in an insulating layer, such as a passivation layer, a planarization layer, or a PDL and the size of a contact hole via which a semiconductor layer is in contact with a metal layer.

[0139] FIG. 11 is a cross-sectional view of a pixel having a structure to increase the capacitance of a data line capacitor according to yet another embodiment. In FIG. 11, a pixel region is divided into 3 regions, i.e., a TFT region (a), a data line capacitor region (b), and a storage capacitor region (c) like in FIG. 8. Here, the same processes as described with reference to FIG. 8 will be briefly described, but different processes will be described in detail.

[0140] Referring to FIG. 11, to form a pixel region according to this embodiment, a substrate 200 is prepared. A buffer layer 205 may be formed on the substrate 200.

[0141] First through third semiconductor layers 207, 208, and 209 are patterned on the buffer layer 205. That is, the first semiconductor layer 207 is patterned in the storage capacitor region (c), the second semiconductor layer 208 is patterned in the TFT region (a), and the third semiconductor layer 209 is patterned in the data line capacitor region (b).

[0142] A gate insulating layer 210 is formed over the entire surface of the substrate 200 including the first through third semiconductor layers 207, 208, and 209. The gate insulating layer 210 may comprise at least one of a silicon oxide (SiO_2) layer, a silicon nitride (SiN_x) layer, a silicon oxynitride (SiO_2N_x) layer, and a multi-layer thereof.

[0143] A first electrode 212 of a storage capacitor C_{st} is formed on the gate insulating layer 210 in the storage capacitor region (c) to overlap the first semiconductor layer 207, and a gate electrode 214 is formed in the TFT region (a) to overlap the second semiconductor layer 208. In this case, while the first electrode 212 and the gate electrode 214 are being formed, scan lines (S_{n-1} , S_n , and E_n of FIG. 4) may also be formed at the same time.

[0144] Thereafter, dopants (n^+ or p^+ type) are implanted into the second semiconductor layer 208 in the TFT region (a) using the gate electrode 214 as a mask. Thus, source and drain regions 208a and 208b are formed in regions that do not overlap the gate electrode 214 formed on the second semiconductor layer 208. In this case, a channel region 208c is defined between the source and drain regions 208a and 208b.

[0145] An interlayer insulating layer 220 is formed over the entire surface of the substrate 200 including the first electrode 212 and the gate electrode 214. Contact holes are formed in the interlayer insulating layer 220 and the gate insulating layer 210 to expose the first through third semiconductor layers 207, 208, and 209. A conductive layer is formed over the substrate 200 including the contact holes and then patterned, thereby forming source and drain electrodes 221 and 223 in the TFT region (a). Then, a data line 225 and a metal 227, which applies a reference voltage to the third semiconductor layer 209, are formed in the data line capacitor region (b). Also, a second electrode 229, which comes into contact with the first semiconductor layer 207, is formed in the storage capacitor region (c).

[0146] Here, the second semiconductor layer 208, the gate insulating layer 210, the gate electrode 214, the source electrode 221, and the drain electrode 223 are formed in the TFT region (a) to produce a TFT. The TFT may, for example, be a driving transistor (M1 of FIG. 4), which generates a driving current, or an emission control transistor (M6 of FIG. 4), which supplies the driving current to the organic light emitting diode OLED.

[0147] Also, the first semiconductor layer 207, the gate insulating layer 210, the first electrode 212, the interlayer insulating layer 220, and the second electrode 229, which is in contact with the first semiconductor layer 207, are formed in the storage capacitor region (c) to form a storage capacitor C_{st} . Further, the third semiconductor layer 209, the gate insulating layer 210, the interlayer insulating layer 220, the data line 225 are stacked in the data line capacitor region (b) to form a first data line capacitor C_{data1} .

[0148] A passivation layer 230 is formed over the entire surface of the substrate 200 including the electrodes 221, 223, 225, 227, and 229 that are formed by patterning the conduc-

tive layer. The passivation layer 230 may comprise at least one of a silicon oxide (SiO_2) layer, a silicon nitride (SiN_x) layer, and a multi-layer thereof. Also, in some embodiments, the passivation layer 230 may not be formed. A first via hole 232 is formed in the passivation layer 230 to expose the drain electrode 223 of the TFT.

[0149] A planarization layer 235 is formed on the passivation layer 230 to reduce the step height, and may be formed of an organic layer, such as a BCB layer, a polyimide layer, or a polyacryl layer. A second via hole 237 is formed in the planarization layer 235 in the TFT region (a) to expose the drain electrode 223 in a region where the first via hole 232 is formed. Also, a third via hole 239 is formed to expose the passivation layer 230.

[0150] A pixel electrode 240 is formed over the entire surface of the substrate 200 including the planarization layer 235 in which the second via hole 237 and the third via hole 239 are formed. The pixel electrode 240 is in contact with the drain electrode 223 that is exposed by the second via hole 237. Also, the pixel electrode 240 is formed over the passivation layer 230 that is exposed by the third via hole 239. Further, the pixel electrode 240 may be formed over the planarization layer 235 if the passivation layer 230 is not formed. Additionally, since the pixel shown in FIG. 11 is a top-emitting type, the pixel electrode 240 may be formed of a light-reflecting conductive layer. In another embodiment, before the pixel electrode 240 is formed, a reflective layer pattern 242 may be further formed, and then the pixel electrode 240 may be formed using a light-transmitting conductive layer. This reflective layer pattern 242 may be spaced apart from the second via hole 237 by a predetermined distance.

[0151] A PDL 245 is formed on the entire surface of the substrate 200 including the pixel electrode 240. An opening 247 is formed in the PDL 245 to expose at least a portion (emission region) of the pixel electrode 240.

[0152] An organic emission layer 250 is formed on the pixel electrode 240 that is exposed by the opening 247. Subsequently, an opposite electrode 255 is formed on the entire surface of the substrate 200 including the organic emission layer 250 and the PDL 245. The opposite electrode 255 may comprise at least one of a light-transmitting conductive layer and a metal reflective layer.

[0153] In the storage capacitor region (c) and the TFT region (a), the pixel electrode 240, the organic emission layer 250, and the opposite electrode 255 form an organic light emitting diode. Also, the data line 225, the passivation layer 230 (and/or the planarization layer 235), and the opposite electrode 255 form a second data line capacitor C_{data2} in the data line capacitor region (b).

[0154] As described above, the pixel according to one embodiment, the first data line capacitor C_{data1} is obtained by forming the third semiconductor layer 209 under the data line 225. Also, the passivation layer 230 and/or the planarization layer 235 are etched through the third via hole 239 in the data line capacitor region (b), and the pixel electrode 240 and the data line 225 constitute the second data line capacitor C_{data2} using only the passivation layer 230 and/or the planarization layer 235 as a dielectric layer.

[0155] Accordingly, the data line capacitor C_{data} has a structure to which the first and second data line capacitors C_{data1} and C_{data2} are connected in parallel about the data line 225. That is, $C_{data} = C_{data1} + C_{data2}$. In applying the pixel structure according to the fourth embodiment of the present invention, the data line capacitor C_{data} has a capacitance of 20 to 50

[PF], which is about 16 times more than in the conventional pixel structure. Therefore, when the pixel driving method using the demultiplexers is used, the gate voltage V_g of a driving transistor becomes substantially equal to the applied data voltage V_{data} , so that the OLED can display exact gray scale and have uniform luminance.

[0156] The capacitance of the data line capacitor C_{data} may be selected by controlling the size of a via hole formed in an insulating layer, such as a passivation layer, a planarization layer, or a PDL and the size of a contact hole via which a semiconductor layer is in contact with a metal layer.

[0157] FIG. 12 is a circuit diagram of another pixel of the OLED shown in FIG. 2.

[0158] Referring to FIG. 12, a pixel 110 includes an organic light emitting diode OLED, which emits light according to a driving current, and a pixel driving circuit 111, which supplies the driving current to the organic light emitting diode OLED. A data voltage V_{data} , which is stored in a data line capacitor C_{datamk} during a data writing period, is applied to the pixel driving circuit 111.

[0159] The pixel driving circuit 111 includes a driving transistor M1, a switching transistor M2, an emission control transistor M3, and a storage capacitor C_{st} . The switching transistor M2 is turned on or off in response to a selection signal applied to a scan line S_n connected to a gate terminal and transmits the data voltage V_{data} from a data line D_{mk} . The driving transistor M1 is connected between a first voltage line V_{dd} and the emission control transistor M3 and has a gate terminal connected to a drain of the switching transistor M2 to generate a driving current corresponding to the data voltage V_{data} . The storage capacitor C_{st} is connected between the first voltage line V_{dd} and the gate terminal of the driving transistor M1 and maintains the data voltage V_{data} for a predetermined time. The emission control transistor M3 is connected between the driving transistor M1 and the organic light emitting diode OLED to transmit the driving current to the organic light emitting diode OLED in response to an emission control signal of an emission control line E_n connected to the gate terminal.

[0160] Operations of the pixel shown in FIG. 12 will now be described. Initially, the data voltage V_{data} is stored in the data line capacitor C_{datamk} during a data writing period. Next, when a selection signal is applied to the scan line S_n , the switching transistor M2 is turned on. In this state, the data voltage V_{data} stored in the data line capacitor C_{datamk} is applied to the gate terminal of the driving transistor M1 via the switching transistor M2, and electric charges equivalent to a difference between a first voltage V_{dd} and the data voltage V_{data} are stored in the storage capacitor C_{st} . The driving transistor M1 operates as a constant current source due to the first voltage V_{dd} applied to a source and the voltage V_{data} applied to a gate and supplies the driving current to the organic light emitting diode OLED.

[0161] In this case, the current supplied to the organic light emitting diode OLED can be expressed as Equation 3:

$$I_{OLED} = k(V_{gs} - V_{th})^2 = k(V_{dd} - V_{data} - V_{th})^2 \quad (3)$$

where I_{OLED} is the current supplied to the organic light emitting diode OLED, V_{gs} is the voltage between the source and gate of the driving transistor M1, V_{th} is the threshold voltage of the driving transistor M1, V_{data} is the data voltage, and k is a constant.

[0162] FIG. 13 is a circuit diagram of yet another pixel of the OLED shown in FIG. 2.

[0163] Referring to FIG. 13, a pixel 110 includes an organic light emitting diode OLED, which emits light according to a driving current, and a pixel driving circuit 111, which supplies the driving current to the organic light emitting diode OLED. A data voltage V_{data} , which is stored in a data line capacitor C_{datamk} during a data writing period, is applied to the pixel driving circuit 111.

[0164] The pixel driving circuit 111 includes first through fifth TFTs M1-M5 and a storage capacitor C_{st} . Here, the first transistor M1 is a switching transistor, and the fourth transistor M4 is a driving transistor. Also, the second transistor M2 is an initialization transistor, and the third transistor M3 is a compensation transistor, which compensates a threshold voltage of the driving transistor M4. Specifically, the first transistor M1 turns on or off in response to a selection signal applied to an n th scan line S_n connected to a gate terminal thereof and transmits or passes the data voltage V_{data} from a data line D_{mk} to the third transistor M3. The second transistor M2 is turned on in response to a selection signal applied to an $(n-1)$ th scan line S_{n-1} connected to a gate terminal thereof and initializes the data voltage V_{data} during an $(n-1)$ th frame period. The third and fourth transistors M3 and M4, which are mirror-type transistors, have commonly connected gate terminals, so that a voltage corresponding to the difference between the data voltage V_{data} supplied from the first transistor M1 and a threshold voltage of the third transistor M3 is applied to the gate terminal of the fourth transistor M4. The storage capacitor C_{st} is connected between a first voltage line V_{dd} and the gate terminal of the fourth transistor M4 and maintains a data voltage $V_{data} - V_{th}$ for a predetermined time. The fifth transistor M5 is connected between the fourth transistor M4 and the organic light emitting diode OLED and supplies the driving current to the organic light emitting diode OLED in response to an emission control signal of an emission control line E_n connected to a gate terminal thereof.

[0165] Operations of the pixel shown in FIG. 13 will now be described. Initially, during an initialization operation, when a low-level selection signal is applied to the $(n-1)$ th scan line S_{n-1} , the second transistor M2 is turned on, so that the data voltage stored in the storage capacitor C_{st} during the $(n-1)$ th frame period is initialized via the second transistor M2.

[0166] During a data writing period, a data voltage V_{data} is stored in the data line capacitor C_{datamk} .

[0167] In a data programming operation, when a low-level selection signal is applied to the scan line S_n , the first transistor M1 is turned on, and the mirror-type third and fourth transistors M3 and M4 are also on. Accordingly, a voltage $V_{data} - V_{th_{M3}}$ corresponding to a difference between the data voltage V_{data} stored in the data line capacitor C_{datamk} and a threshold voltage $V_{th_{M3}}$ of the third transistor M3 is applied to the gate of the fourth transistor M4.

[0168] Finally, in an emission operation, when a low-level emission control signal is applied to the emission control line E_n , the fifth transistor M5 is turned on in response to an emission control signal, so that a driving current corresponding to the first voltage V_{dd} applied to a source terminal of the fourth transistor M4 and the voltage $V_{data} - V_{th_{M3}}$ applied to the gate terminal thereof is applied to the organic light emitting diode OLED. Thus, the organic light emitting diode OLED emits light according to the data signal.

[0169] The driving current supplied to the organic light emitting diode OLED can be expressed as Equation 4:

$$I_{OLED} = k(V_{GS_{M4}} - V_{th_{M4}})^2 = k(V_{dd} - V_{data} + V_{th_{M3}} - V_{th_{M4}})^2 = k(V_{dd} - V_{data})^2 \quad (4)$$

where I_{OLED} is the current supplied to the organic light emitting diode OLED, $V_{GS_{M4}}$ is the voltage between the source and gate of the fourth transistor M4, $V_{th_{M3}}$ is the threshold voltage of the third transistor M3, $V_{th_{M4}}$ is the threshold voltage of the fourth transistor M4, V_{data} is the data voltage, and k is a constant. Here, when the third transistor M3 is equal in threshold voltage to the fourth transistor M4, i.e., when $V_{th_{M3}} = V_{th_{M4}}$, the threshold voltages of the transistors can be compensated, thus the organic light emitting diode OLED can keep the driving current constant.

[0170] FIG. 14 is a circuit diagram of still another pixel of the OLED shown in FIG. 2.

[0171] Referring to FIG. 14, a pixel 110 includes an organic light emitting diode OLED, which emits light according to a driving current, and a pixel driving circuit 111, which supplies the driving current to the organic light emitting diode OLED. A data voltage V_{data} , which is stored in a data line capacitor $C_{data_{mk}}$ during a data writing period, is applied to the pixel driving circuit 111, which includes first through fifth TFTs M1-M5 and two capacitors C_{st} and C_{vth} .

[0172] The first transistor M1, which is a driving transistor for driving the organic light emitting diode OLED, is connected between a first voltage line V_{dd} and the fourth transistor M4 and controls the driving current passing through the organic light emitting diode OLED using a voltage applied to a gate thereof. The second transistor M2 diode-connects the first transistor M1 in response to a selection signal supplied from an $(n-1)$ th scan line S_{n-1} .

[0173] One node A of the threshold voltage compensation capacitor C_{vth} is connected to the gate of the first transistor M1, and the storage capacitor C_{st} and the fifth transistor M5 are connected in parallel between the other node B of the threshold voltage compensation capacitor C_{vth} and the first voltage line V_{dd} . The fifth transistor M5 applies the first voltage V_{dd} to the node B of the threshold voltage compensation capacitor C_{vth} in response to the selection signal supplied from the $(n-1)$ th scan line S_{n-1} .

[0174] The third transistor M3 transmits the data voltage V_{data} supplied from a data line D_{mk} to the node B of the threshold voltage compensation capacitor C_{vth} in response to a selection signal supplied from an n th scan line S_n . The fourth transistor M4 is connected between the first transistor M1 and the organic light emitting diode OLED and connects or disconnects the first transistor M1 and the organic light emitting diode OLED in response to an emission control signal supplied from an emission control line E_n .

[0175] Operations of the foregoing pixel shown in FIG. 14 will now be described. Initially, when a low-level selection signal is applied to the $(n-1)$ th scan line S_{n-1} , the second transistor M2 is turned on so that the first transistor M1 is diode-connected. Thus, a voltage between the gate and source of the first transistor M1 is changed until it reaches a threshold voltage V_{th} of the first transistor M1. In this case, since the source of the first transistor M1 is connected to the first voltage V_{dd} , a voltage applied to the gate of the first transistor M1, i.e., a voltage applied to the node A of the threshold voltage compensation capacitor C_{vth} becomes a difference between the first voltage V_{dd} and the threshold voltage V_{th} . Also, the fifth transistor M5 is turned on so that the first voltage V_{dd} is applied to the node B of the storage capacitor

C_{vth} , thus a voltage $V_{C_{vth}}$ charged in the threshold voltage compensation capacitor C_{vth} can be expressed as Equation 5:

$$V_{C_{vth}} = V_B - V_A = V_{dd} - (V_{dd} - V_{th}) = V_{th} \quad (5)$$

where $V_{C_{vth}}$ is the voltage charged in the capacitor C_{vth} , V_A is the voltage applied to the node A of the capacitor C_{vth} , and V_B is the voltage applied to the node B of the capacitor C_{vth} .

[0176] Next, during a data writing period, the data voltage V_{data} is stored in the data line capacitor $C_{data_{mk}}$ via the data line D_{mk} . Thereafter, when a low-level selection signal is applied to the n th scan line S_n , the third transistor M3 is turned on so that the data voltage V_{data} is applied to the node B. Also, since a voltage corresponding to the threshold voltage V_{th} of the first transistor M1 is charged in the threshold voltage compensation capacitor C_{vth} , a voltage corresponding to a difference between the data voltage V_{data} and the threshold voltage V_{th} of the first transistor M1 is applied to the gate of the first transistor M1.

[0177] Finally, the fourth transistor M4 is turned on in response to a low-level signal supplied from the emission control line E_n , so that a current I_{OLED} according to a gate-source voltage V_{GS} of the first transistor M1 is applied to the organic light emitting diode OLED. Thus, the organic light emitting diode OLED emits light according to the applied data.

[0178] The current I_{OLED} supplied to the organic light emitting diode OLED can be expressed as Equation 6:

$$I_{OLED} = k(V_{GS} - V_{th})^2 = k(V_{dd} - V_{data} + V_{th}) - V_{th})^2 = k(V_{dd} - V_{data})^2 \quad (6)$$

where I_{OLED} is the current supplied to the organic light emitting diode OLED, V_{GS} is the voltage between the source and gate of the first transistor M1, V_{th} is the threshold voltage of the first transistor M1, V_{data} is the data voltage, and k is a constant. As described above, since the current I_{OLED} supplied to the organic light emitting diode OLED is determined by the first voltage V_{dd} and the data voltage V_{data} , luminance non-uniformity of the driving transistor M1 caused by a difference in threshold voltage is resolved.

[0179] As described above, the OLED can reduce the number of output lines and the production cost because data signals supplied from one output line can be divided and applied to a plurality of data lines using demultiplexers.

[0180] Also, voltages corresponding to data signals are sequentially charged in data line capacitors and the charged voltages are applied to pixels at the same time, so that the OLED can display an image with uniform luminance.

[0181] Further, a scan period for which a scan signal is supplied does not overlap a data writing period for which a data signal is supplied, thus the OLED can stably display an image. In addition, as the capacitance of a data line capacitor formed in a data line is much greater than the capacitance of a storage capacitor, the OLED can display exact gray scale and have uniform luminance.

While the above detailed description has shown, described, and pointed out novel features as applied to various embodiments, it will be understood that various omissions, substitutions, and changes in the form and details of the device or process illustrated may be made by those skilled in the art without departing from the scope of the invention. As will be recognized, the present invention may be embodied within a form that does not provide all of the features and benefits set forth herein, as some features may be used or practiced separately from others. Additionally certain features may be prac-

ticed in combinations not specifically described in any one embodiment discussed herein.

What is claimed is:

1. An organic light emitting display (OLED) comprising:
 - a substrate;
 - a storage capacitor region, a thin film transistor region, and a data line capacitor region each formed on the substrate;
 - a storage capacitor formed in the storage capacitor region, the storage capacitor comprising:
 - a first semiconductor layer formed on the substrate;
 - a gate insulating layer formed on the first semiconductor layer;
 - a first electrode formed on the gate insulating layer;
 - an interlayer insulating layer formed on the first electrode; and
 - a second electrode formed on the interlayer insulating layer, wherein the second electrode is electrically connected to the first semiconductor layer;
 - a thin film transistor formed in the thin film transistor region, the thin film transistor comprising:
 - a second semiconductor layer formed on the substrate;
 - a gate insulating layer formed on the second semiconductor layer;
 - a gate electrode formed on the gate insulating layer;
 - a source electrode formed on the gate insulating layer; and
 - a drain electrode formed on the gate insulating layer;
 - a first data line capacitor formed in the data line capacitor region, the first data line capacitor comprising:
 - a third semiconductor layer formed on the substrate;
 - a gate insulating layer formed on the third semiconductor layer;
 - an interlayer insulating layer formed on the gate insulating layer; and
 - a data line formed on the interlayer insulating layer,
 - an organic light emitting diode formed on the storage capacitor and the thin film transistor and comprising:
 - a pixel electrode connected to one of the source and drain electrodes;
 - an organic emission layer formed on the pixel electrode; and
 - an opposite electrode formed on the storage capacitor, the thin film transistor, and the first data line capacitor; and
 - a second data line capacitor formed on the data line capacitor, the second data line capacitor comprising:
 - the data line;
 - an insulating layer formed over the data line; and
 - the opposite electrode.
2. The OLED according to claim 1, wherein the insulating layer of the second data line capacitor comprises a passivation layer comprising at least one of a silicon oxide (SiO_2) layer, a silicon nitride (SiN_x) layer, and a multi-layer thereof.
3. The OLED according to claim 2, wherein a third data line capacitor comprises the first and second data line capacitors.
4. The OLED according to claim 1, wherein the insulating layer of the second data line capacitor comprises a planarization layer, comprising at least one of a benzocyclobutene (BCB) layer, a polyimide layer, and a polyacryl layer.
5. The OLED according to claim 4, wherein a third data line capacitor comprises the first and second data line capacitors.
6. The OLED according to claim 1, wherein the insulating layer of the second data line capacitor comprises a pixel defining layer comprising at least one of benzocyclobutene (BCB), acrylic photoresist, phenolic photoresist, and imidic photoresist.
7. The OLED according to claim 6, wherein a third data line capacitor comprises the first and second data line capacitors.
8. The OLED according to claim 7, wherein the third data line capacitor has a larger capacitance than the storage capacitor.
9. The OLED according to claim 8, wherein the third data line capacitor has a capacitance of about 20 pF to about 50 pF.
10. The OLED according to claim 9, wherein the capacitance of the third data line capacitor depends at least in part on at least one of the size of a contact hole, the size of a via hole, and the thickness of at least one of the passivation layer, the planarization layer, and the pixel defining layer.
11. An organic light emitting display (OLED) comprising:
 - a substrate;
 - a storage capacitor region, a thin film transistor region, and a data line capacitor region each formed on the substrate;
 - a storage capacitor formed in the storage capacitor region, the storage capacitor comprising:
 - a first semiconductor layer formed on the substrate;
 - a gate insulating layer formed on the first semiconductor layer;
 - a first electrode formed on the gate insulating layer;
 - an interlayer insulating layer formed on the first electrode; and
 - a second electrode formed on the interlayer insulating layer, wherein the second electrode is electrically connected to the first semiconductor layer;
 - a thin film transistor formed in the thin film transistor region, the thin film transistor comprising:
 - a second semiconductor layer formed on the substrate;
 - a gate insulating layer formed on the second semiconductor layer;
 - a gate electrode formed on the gate insulating layer;
 - a source electrode formed on the gate insulating layer; and
 - a drain electrode formed on the gate insulating layer;
 - a first data line capacitor formed in the data line capacitor region, the first data line capacitor comprising:
 - a third semiconductor layer formed on the substrate;
 - a gate insulating layer formed on the third semiconductor layer;
 - an interlayer insulating layer formed on the gate insulating layer; and
 - a data line formed on the interlayer insulating layer;
 - an organic light emitting diode formed on the storage capacitor and the thin film transistor and comprising:
 - a pixel electrode connected to one of the source and drain electrodes;
 - an organic emission layer formed on the pixel electrode; and
 - an opposite electrode formed on the storage capacitor, the thin film transistor, and the first data line capacitor; and
 - a second data line capacitor formed on the data line capacitor, the second data line capacitor comprising:
 - the data line;
 - an insulating layer formed over the data line; and
 - the pixel electrode.

12. The OLED according to claim **11**, wherein the insulating layer of the second data line capacitor comprises a passivation layer comprising at least one of a silicon oxide (SiO_2) layer, a silicon nitride (SiN_x) layer, and a multi-layer thereof.

13. The OLED according to claim **12**, wherein a third data line capacitor comprises the first and second data line capacitors.

14. The OLED according to claim **11**, wherein the insulating layer of the second data line capacitor comprises a planarization layer, comprising at least one of a benzocyclobutene (BCB) layer, a polyimide layer, and a polyacryl layer.

15. The OLED according to claim **14**, wherein a third data line capacitor comprises the first and second data line capacitors.

16. The OLED according to claim **15**, wherein the third data line capacitor has a larger capacitance than the storage capacitor.

17. The OLED according to claim **16**, wherein the third data line capacitor has a capacitance of about 20 pF to about 50 pF.

18. The OLED according to claim **17**, wherein the capacitance of the third data line capacitor depends at least in part on at least one of the size of a contact hole, the size of a via hole, and the thickness of at least one of the passivation layer, the planarization layer, and the pixel defining layer.

19. An organic light emitting display (OLED) comprising:
a substrate;

a storage capacitor formed in a first region of the substrate;
a thin film transistor formed in a second region of the substrate;

a first data line capacitor formed in a third region of the substrate;

an organic light emitting diode formed on the storage capacitor and the thin film transistor; and

a second data line capacitor formed on the data line capacitor, the second data line capacitor comprising:

the data line; and

the opposite electrode.

20. An organic light emitting display (OLED) comprising:
a substrate;

a storage capacitor formed in a first region of the substrate;

a thin film transistor formed in a second region of the substrate;

a first data line capacitor formed in a third region of the substrate;

an organic light emitting diode formed on the storage capacitor and the thin film transistor; and

a second data line capacitor formed on the data line capacitor, the second data line capacitor comprising:

the data line; and

the pixel electrode.

* * * * *

专利名称(译)	有机发光显示器		
公开(公告)号	US20110108844A1	公开(公告)日	2011-05-12
申请号	US13/007371	申请日	2011-01-14
[标]申请(专利权)人(译)	三星显示有限公司		
申请(专利权)人(译)	三星移动显示器有限公司.		
当前申请(专利权)人(译)	三星DISPLAY CO. , LTD.		
[标]发明人	KWAK WON KYU KIM YANG WAN		
发明人	KWAK, WON-KYU KIM, YANG-WAN		
IPC分类号	H01L51/50		
CPC分类号	G09G3/3233 G09G2300/0819 G09G2300/0842 H01L27/3244 G09G2300/0861 G09G2310/0297 G09G2320/043 G09G2300/0852 H01L27/3265 H01L51/5218		
优先权	1020050039895 2005-05-12 KR		
其他公开文献	US8797238		
外部链接	Espacenet USPTO		

摘要(译)

公开了一种有机发光显示器 (OLED)。OLED包括形成在基板的第一区域中的存储电容器，形成在基板的第二区域中的薄膜晶体管，形成在基板的第三区域中的第一数据线电容器，形成在基板的第三区域中的有机发光二极管。存储电容器和薄膜晶体管，以及形成在数据线电容器上的第二数据线电容器。

